

- PT** Oscilobatente
- ES** Oscilobatiente
- EN** Tilt & Turn
- FR** Oscillobattant

EZ CUT

Cortar directamente na barra a medida de H1, H2 e LF. O Oscilo GNS é fornecido pronto a ser instalado.

Cortar directamente el la barra la medida de H1, H2 y LF. El Oscilo GNS es sumini er instalado.

Directly cut the measures H1, H2 and LF in the nylon bars. The GNS Tilt and Turn is supplied ready to be installed.

Coupez directement les mesures H1, H2 et LF dans les tringles en nylon. Le oscilo-batant GNS est fourni prêt à être installé.

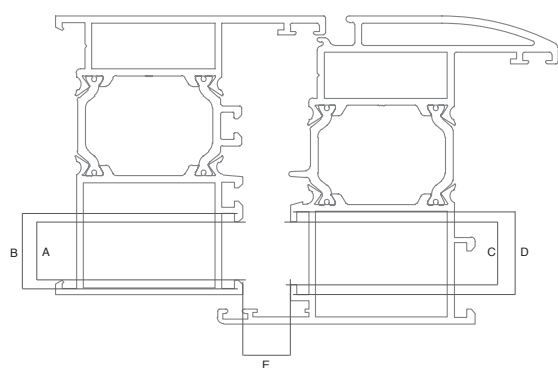
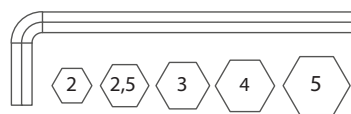
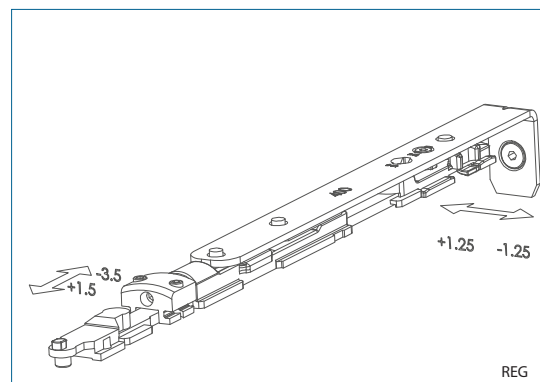
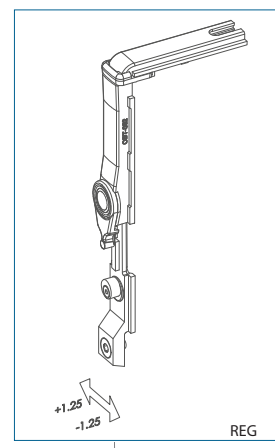

A	B	C	D	E
14	18			
13,5	16,8	15	20	11,5
12	15			
10	14			

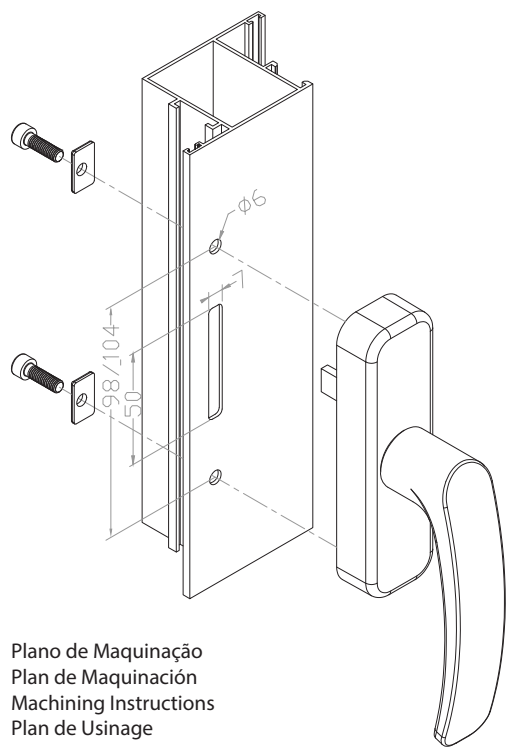

Plano de Maquinação
Plan de Maquiniación
Machining Instructions
Plan de Usinage

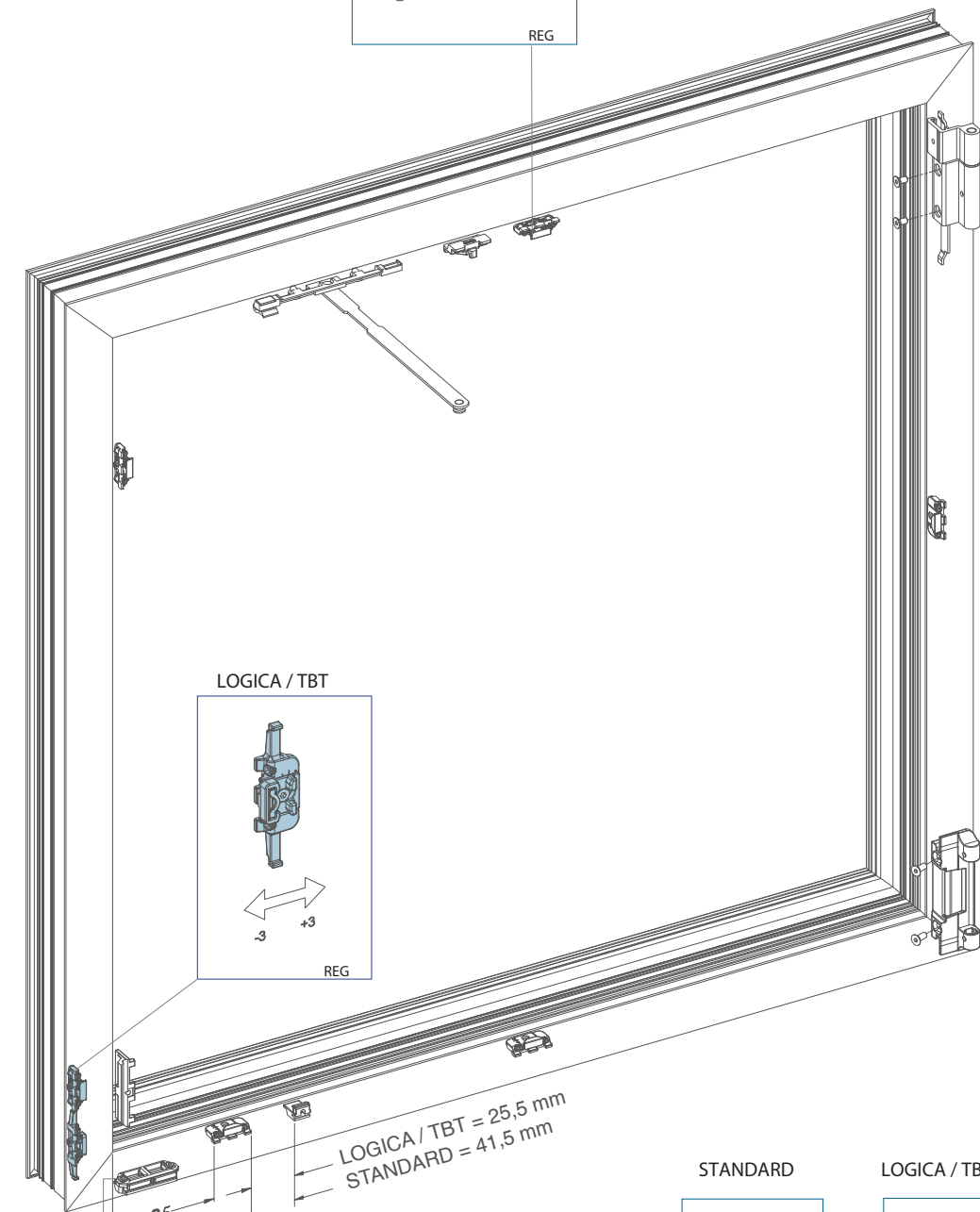

LOGICA / TBT

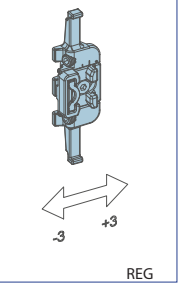

LOGICA / TBT = 25,5 mm
STANDARD = 41,5 mm

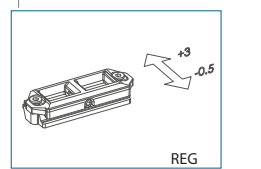

STANDARD

STANDARD

LOGICA / TBT

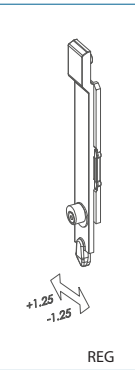

REG

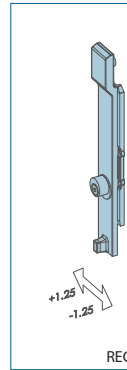

REG

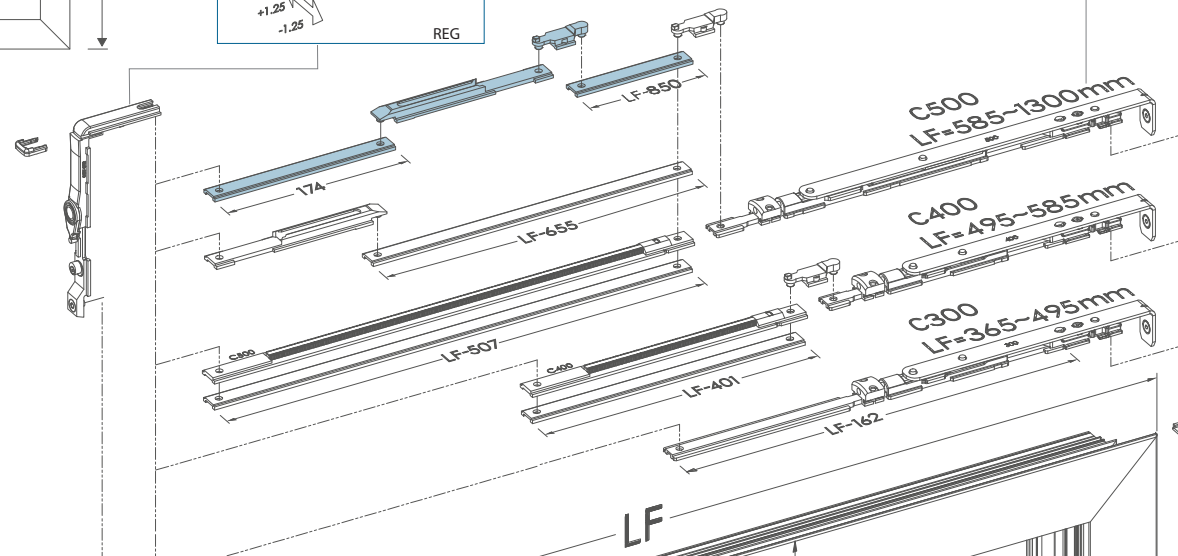

LF

H2

H1

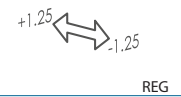

Regulação
Regulación
Regulation
Regulation

GNS
BY SOTRALU GROUP

ARN 89

www.ingns.com

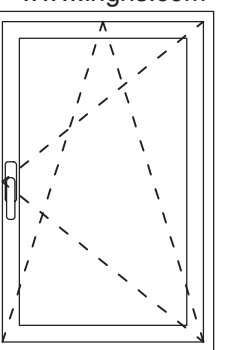

EN - 13126

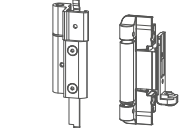

Kit Dobradiças
Kit Bisagras
Hinges Kit
Kit Paumelle

5203

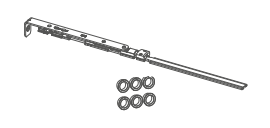

Compasso 300
Compas 300
Compass 300
Compass 300

C300

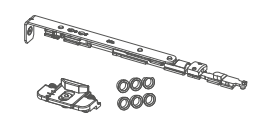

Compasso 400
Compas 400
Compass 400
Compass 400

C400

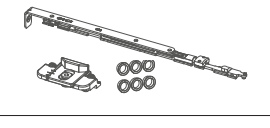

Compasso 500
Compas 500
Compass 500
Compass 500

C500

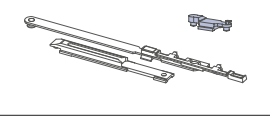

Compasso Suplementar
Compas Suplementar
Additional Arm
Compass Supplémentaire

5209 TBT
5209 TnT

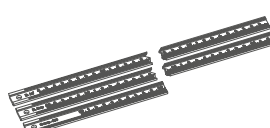

Réguas de Corte Rápido
Reglas de Corte Rápido
Easy Cut Assembly Bars
Tringles de Coupe Rapide

5230

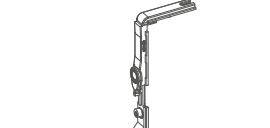

Esquadro Anti-Falsa Manobra
Angulo Anti-Falsa Maniobra
Anti-False Maneuver Angle
Angle Anti-Faux Manoeuvre

5234

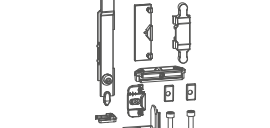

Kit Peças Oscilo Tradicional
Kit Piezas Oscilo Tradicional
Standard Tilt and Turn Components
Kit de Pièces pour Oscilo Traditionel

5231

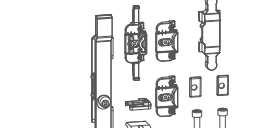

Kit Peças Oscilo Manobra Lógica
Kit Piezas Oscilo Maniobra Lógica
Tilt Before Turn Components Kit
Kit de Pièces pour Oscilo Manoeuvre Logique

5232

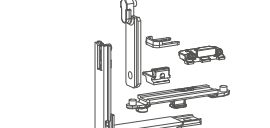

Ângulo Reenvio Inferior
Angulo Reenvio Inferior
Bottom Corner Transmission
Renvoi D'Angle Inférieure

5219

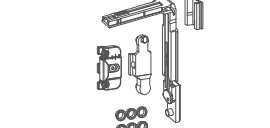

Ponto de fecho Adicional Vertical
Punto de Cierre Adicional Vertical
Additional Vertical Locking Point
Point de Fermeture Vertical Supplémentaire

5211

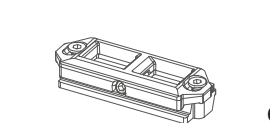

Ponto de Fecho Duplo com Regulação
Punto de Cierre Duplo con regulación
Double Locking Point with Regulation
Point de Fermeture Double avec Réglage

OBT021

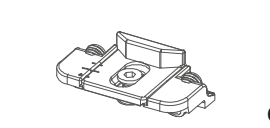

Ponto de Fecho
Punto de Cierre
Locking Point
Point de Fermeture

OBT025

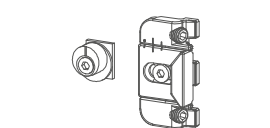

Ponto de Fecho Adicional
Punto de Cierre Adicional
Additional Locking Point
Point de Fermeture Aditionel

5233

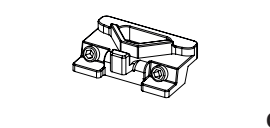

Sistema de Micro-Ventilação
Sistema de Micro-Ventilación
Micro-Ventilation System
Système de Micro-Ventilation

OBT081

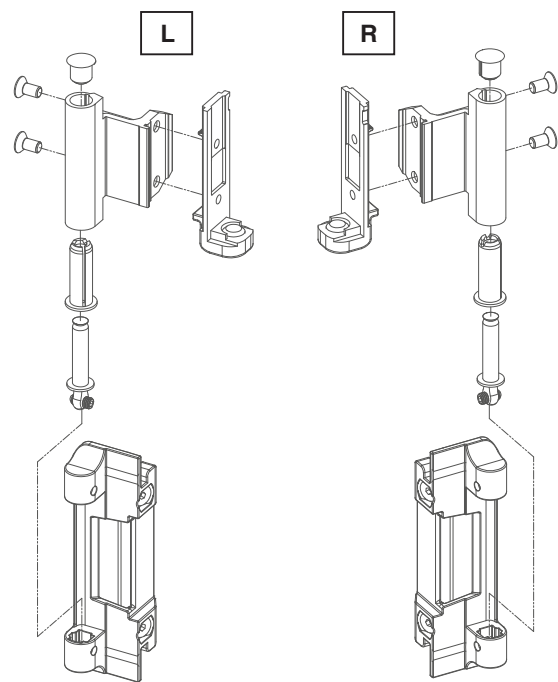

Instruções para Reverter a Mão da Dobradiça Inferior.
Instrucciones para reverter la mano de la Bisagra Inferior.
Instructions to Reverse the Bottom Hinge Hand.
Instructions pour inverser la main de la Paumelle Inferior.

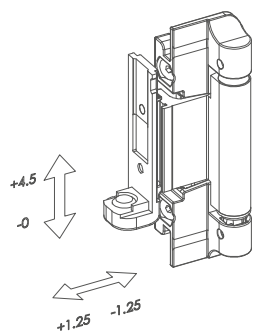

Regulação Dobradiça Inferior
Regulación Bisagra Inferior
Bottom Hinge Regulation
Regulation Paumelle Inferior

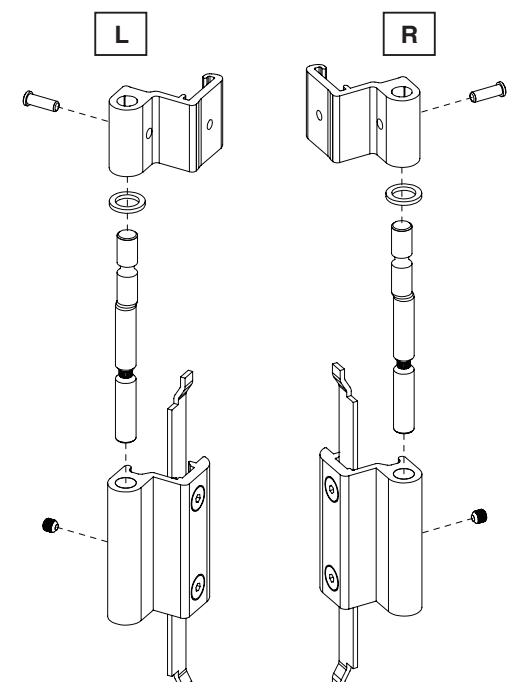

Instruções para Reverter a Mão da Dobradiça Superior.
Instrucciones para reverter la mano de la Bisagra Superior.
Instructions to Reverse the Upper Hinge Hand.
Instructions pour inverser la main de la Paumelle Supérieure.

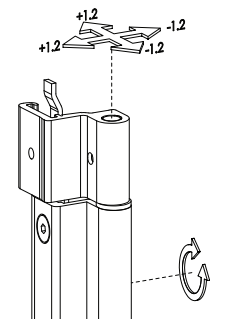

Regulação Dobradiça Superior.
Regulación Bisagra Superior.
Top Hinge Regulation.
Regulation Paumelle Supérieure.

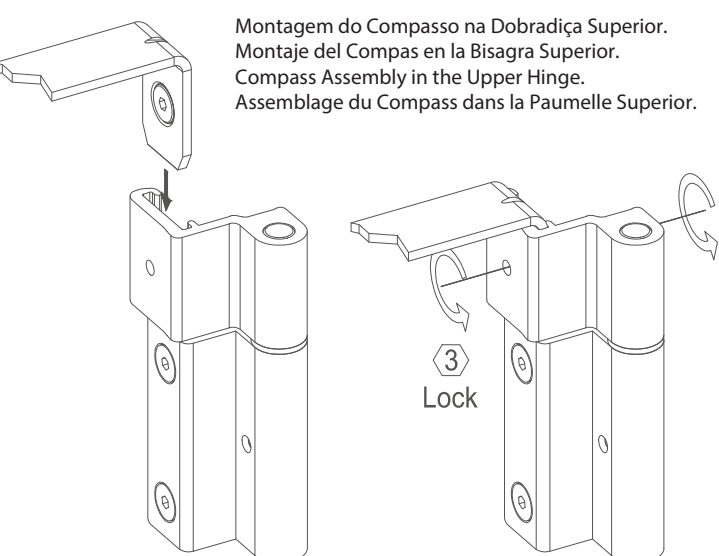

Montagem do Compasso na Dobradiça Superior.
Montaje del Compas en la Bisagra Superior.
Compass Assembly in the Upper Hinge.
Assemblage du Compass dans la Paumelle Superior.

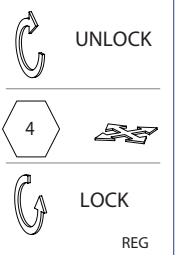

Ordem de Montagem Sequencial | Instrucciones de Montaje Secuencial
Sequential Assembly Instructions | Instructions de Montage Séquentiel

ARO | MARCO | FRAME | DORMANT

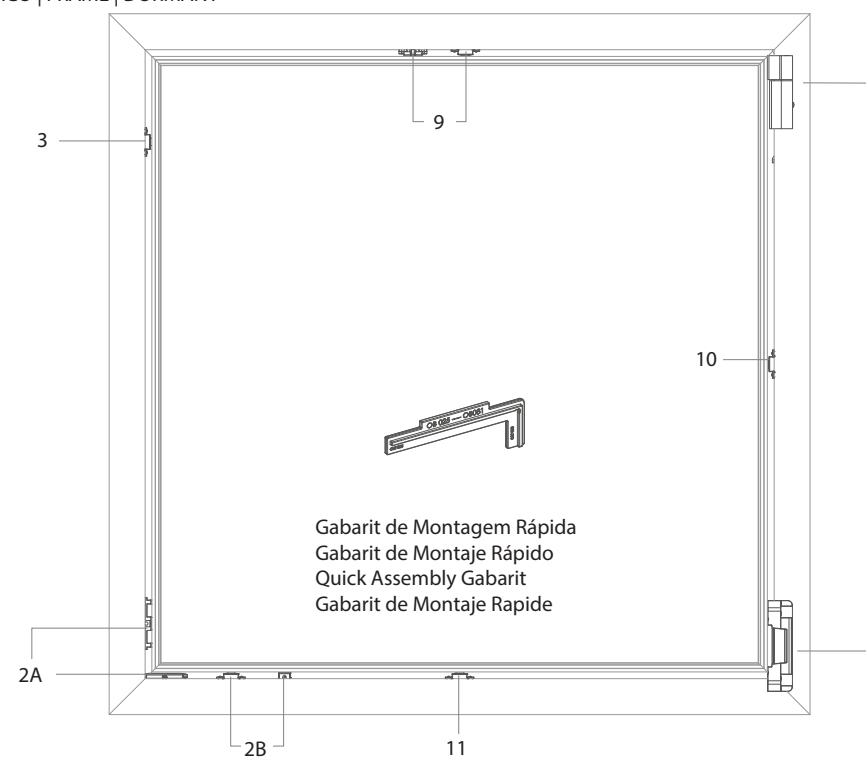

LOGICA / TBT

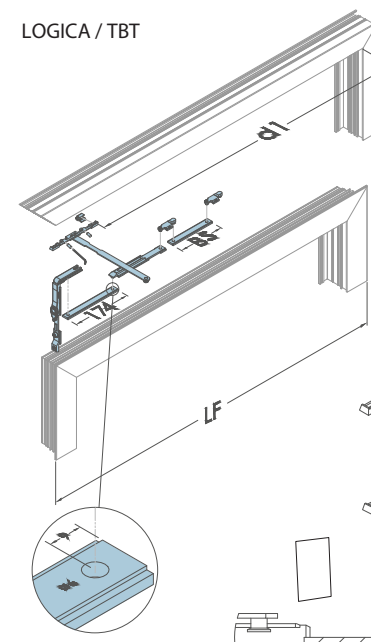

Compasso Suplementar para Manobra Lógica.
 Compas Suplementar para Maniobra Logica
 Tilt Before Turn Additional Compass
 Compas Supplémentaire pour Manoeuvre Logique

STANDARD

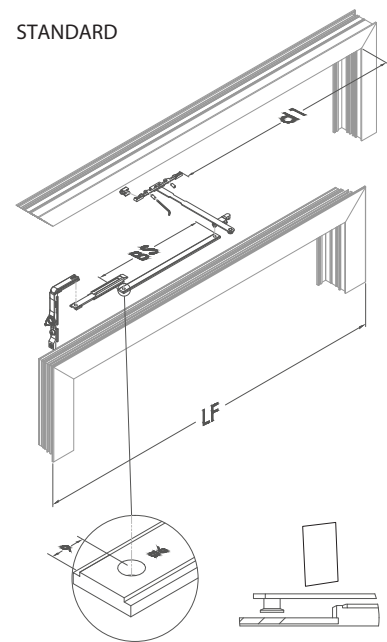

Compasso Suplementar
 Compas Suplementar
 Additional Arm
 Compas Supplémentaire

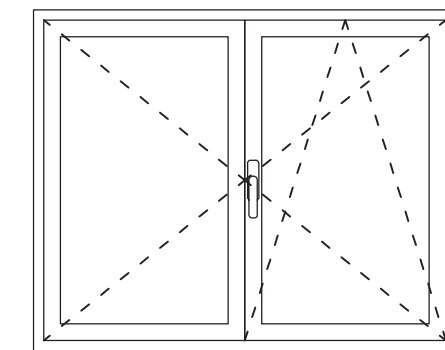

Min LF 950mm
 BS = LF-850
 d1 = LF-162

Min LF 900mm
 BS = LF-655
 d1 = LF-408

FOLHA | HOJA | SASH | OUVRANT

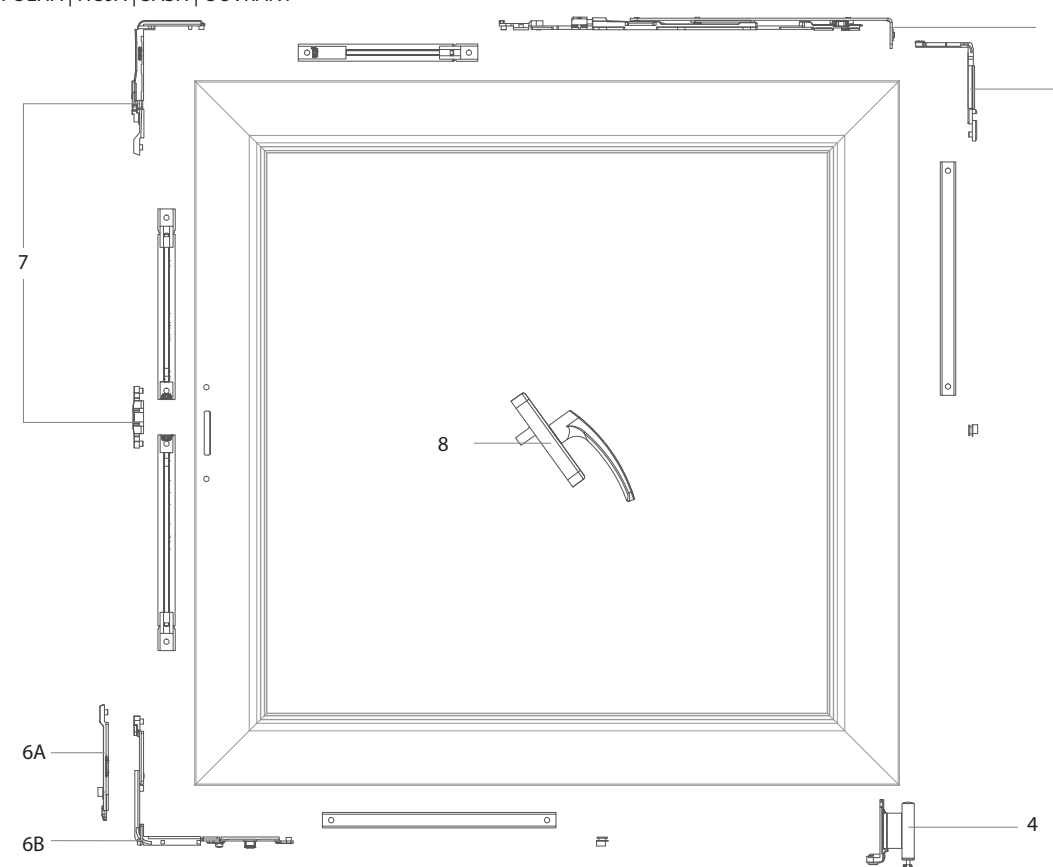

Espessura máxima do vidro. | Espesura máxima del vidrio
Maximum Glass Thickness | Épaisseur de Verre Maximum
120 Kg

H	2400	2300	2200	2100	2000	1900	1800	1700	1600	1500	1400	1300	1200	1100	1000	900	800	700	600	500	450
370	44	44	44	44	44	44	44	44	44	44	44	44	44	44	44	44	44	44	44	44	44
400	44	44	44	44	44	44	44	44	44	44	44	44	44	44	44	44	44	44	44	44	44
500	44	44	44	44	44	44	44	44	44	44	44	44	44	44	44	44	44	44	44	44	44
600	44	44	44	44	44	44	44	44	44	44	44	44	44	44	44	44	44	44	44	44	44
700	44	44	44	44	44	44	44	44	44	44	44	44	44	44	44	44	44	44	44	44	44
800	44	44	44	44	44	44	44	44	44	44	44	44	44	44	44	44	44	44	44	44	44
900	44	44	44	44	44	44	44	44	44	44	44	44	44	44	44	44	44	44	44	44	44
1000	44	44	44	44	44	44	44	44	44	44	44	44	44	44	44	44	44	44	44	44	44
1100	44	44	44	44	44	44	44	44	44	44	44	44	44	44	44	44	44	44	44	44	44
1200	44	44	44	44	44	44	44	44	44	44	44	44	44	44	44	44	44	44	44	44	44
1300	44	44	44	44	44	44	44	44	44	44	44	44	44	44	44	44	44	44	44	44	44
1400	44	44	44	44	44	44	44	44	44	44	44	44	44	44	44	44	44	44	44	44	44
1500	44	44	44	44	44	44	44	44	44	44	44	44	44	44	44	44	44	44	44	44	44
1600	44	44	44	44	44	44	44	44	44	44	44	44	44	44	44	44	44	44	44	44	44
1700	44	44	44	44	44	44	44	44	44	44	44	44	44	44	44	44	44	44	44	44	44

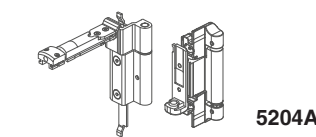
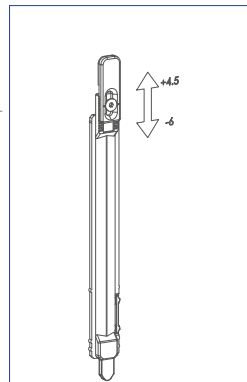
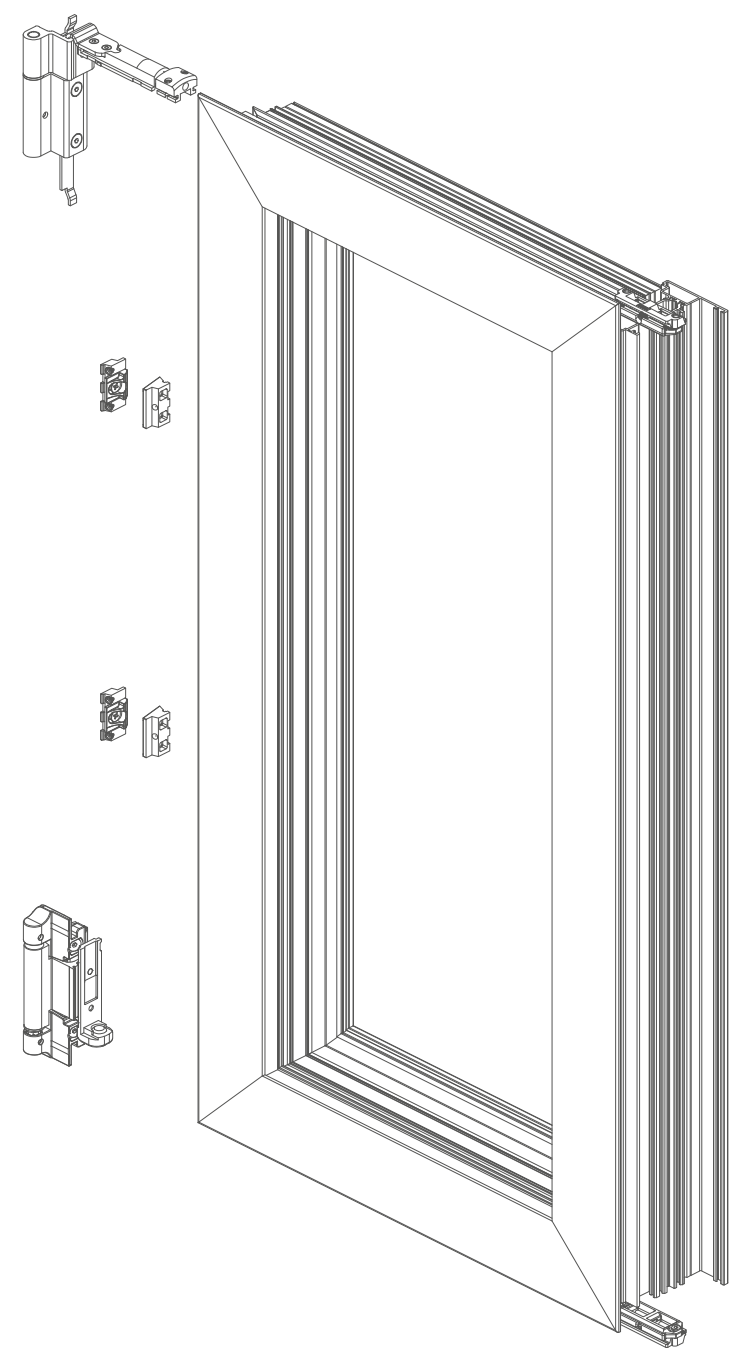
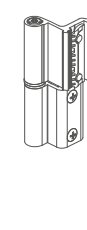
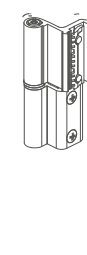

Kit Dobradiça de Segunda Folha
 Kit Bisagra de Segunda Hoja
 Second Sash Hinge Kit
 Kit Paumelle Deuxième Vantail

5204A

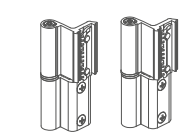

KIT FU2P

Dobraçã Camara Europeia
 Bisagra Canal Europeo
 Euro Groove Hinge
 Paumelle Gorge Européenne

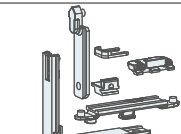

5219

Kit Segunda Folha Manobra Lógica
 Ki Segunda Hoja Maniobra Lógica
 Tilt Before Turn Second Sash Kit
 Kit Deuxième Vantail Manoeuvre Logique



7000

Kit Fecho Bidireccional
 Kit Pasador Bidireccional
 Second Sash Bidirectional Lock
 Verrou Bidirectionel Deuxième Vanatil

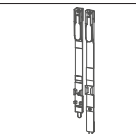

5206

Kit Fecho Segunda Folha Zamak
 Kit Pasador Segunda Hoja Zamak
 Second Sash Zamak Bolt Kit
 Kit Verrou Zamak Deuxième Vantail

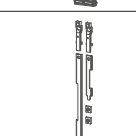

5207

Kit Fecho Segunda Folha Aluminio
 Kit Pasador Segunda Hoja Aluminio
 Second Sash Aluminium Bolt Kit
 Kit Verrou Aluminium Deuxième Vantail

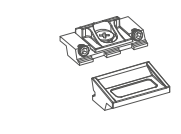

5215

Ponto de Fecho Adicional
 Punto de Cierre Adicional
 Additional Locking Point
 Point de Fermeture Supplémentaire

STANDARD

Montagem Kit Manobra Tradicional
 Montaje Kit Maniobra Tradicional
 Standard Maneuver Kit Assembly
 Montage Kit Manoeuvre Traditionel

LOGICA / TBT

Montagem Kit Manobra Lógica
 Montaje Kit Maniobra Lógica
 Tilt Before Turn Kit Assembly
 Montage Kit Manoeuvre Logique

STANDARD

Compasso - De Manobra Tradicional para Manobra Lógica
 Compas - De Maniobra Tradicional a Maniobra Lógica
 Compass - From Tilt and Turn to Tilt Before Turn
 Compass - Du Manoeuvre Traditionel a Manoeuvre Logic



ARN 89