

FECHADURAS
LOCKS
CERRADURAS
SERRURES



01

SUMÁRIO DE ÍCONES

ICONS SUMMARY
ÍNDICE DE ICONOS
RÉSUMÉ DES ICÔNES

Embalagens / Packaging / Embalajes / Emballages

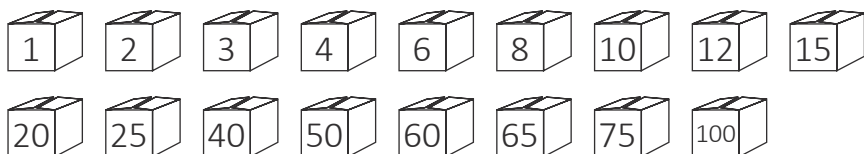
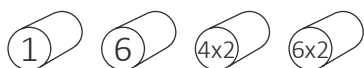

Materiais / Materials / Materiales / Matériels



Acabamentos / Finishings / Acabados / Finitions



Cores / Colors / Colores / Couleurs



? Cor por Encomenda / Color by Request / Color por Pedido / Couleur sur Commande

● Refs. 6200 Mate (Verde 61) / 6192 (Verde 92) / 6005 / 6005 Mate / 6009

● Refs. 1013 / 1015 / 1015 Mate

● Refs. 8014 / 8017 / 8146 Mate

● Refs. 7011 / 7012 / 7035 Mate / 7040 / 7042 / 7048 / 9002 / 9006

○ Refs. 9001 / 9003 / 9010 / 9110 Mate

● Refs. 3003 / 3005

● Refs. 5010 / 5013

● Refs. 1011

● ● ●

Regulação / Regulation / Regulación / Régulation



Caixas estreitas para perfis de corte térmico.

Narrow boxes for thermal break profiles.

Cajas estrechas para perfiles de corte térmico.

Boîtes étroites pour profils à coupure thermique.

SUMÁRIO DE ÍCONES

ICONS SUMMARY
ÍNDICE DE ICONOS
RÉSUMÉ DES ICÔNES

Medidas / Sizes / Mesures



Distância do meio do cilindro até à frente da fechadura.
Distance from the center of the cylinder to the front of the lock.
Distancia desde el centro del cilindro hasta el frente de la cerradura.
Distance du centre du cylindre jusqu'à l'avant de la serrure.



Distância do meio do quadrado até ao centro do cilindro.
Distance from the center of the square to the center of the cylinder.
Distancia desde el centro del cuadrado hasta el centro del cilindro.
Distance du milieu du carré jusqu'au centre du cylindre.



Testa lisa / Testa em U.
Flat shape / U shape.
Frente lisa / Frente en U.
Tête plate / Tête U.

Conceitos / Concepts / Conceptos



Instalação rápida da dobradiça no perfil.
Quick installation of the hinge on the profile.

Instalación rápida de la bisagra en el perfil.
Installation rapide de la charnière sur le profil.



Caixas estreitas para perfis de corte térmico.
Narrow boxes for thermal break profiles.

Cajas estrechas para perfiles de corte térmico.
Boîtes étroites pour profils à rupture de pont thermique.



Flexibilidade e facilidade na permuta de trinco para o rolete ou vice-versa.
Flexibility and facility on the swap latch for the roller and vice versa.
Flexibilidad y facilidad en el intercambio de pestillo por el rodillo o viceversa.
Flexibilité et facilité d'échange du pêne pour le loquet ou vice versa.

As imagens contidas neste catálogo, destinam-se à promoção dos produtos e fruto do seu constante desenvolvimento, podem não refletir a forma como num dado momento, um produto é fornecido ou embalado, pelo que por si não constituem uma obrigação legal. Antes de cada encomenda é sempre necessário confirmar o seu estado atual.

The images contained in this catalog are intended for the promotion of products and, due to their constant development, may not reflect how a product is supplied or packaged at any given moment. Therefore, they do not constitute a legal obligation. Before each order, it is always necessary to confirm its current status.

Las imágenes contenidas en este catálogo están destinadas a la promoción de los productos y, debido a su constante desarrollo, pueden no reflejar la forma en que, en un momento dado, se suministra o empaqueta un producto, por lo que no constituyen una obligación legal por sí mismas. Antes de cada pedido, siempre es necesario confirmar su estado actual.

Les images contenues dans ce catalogue sont destinées à promouvoir les produits et, en raison de leur développement constant, elles peuvent ne pas refléter la manière dont un produit est fourni ou emballé à un moment donné, et donc elles ne constituent pas une obligation légale. Avant chaque commande, il est toujours nécessaire de confirmer son état actuel.

Fechaduras Multipunto / Multipoint Locks / Cerraduras de Multipunto / Serrures Multipoint

7615	04
7706 - 7707	05
7709	06
7715 - 7715 R	07
7715 ALU	08
7717 - 7717 R	09
7799 - 7799 A- 7799 R	10
7796 - 7796 A - 7799 G	11

Fechaduras Monopunto / Monopoint Locks / Cerraduras de Monopunto / Serrures Monopoint

7716 - 7716 R	12
7716 G - 7716 L - 7716 R - 7716 SG - 7716 T	13
7791 - 7791 A - 7791 S - 7792 - 7792 R	14
7794 - 7794 A - 7794 R	15
7795 - 7795 R - 7798 - 7798 R	16
9791 - 9791 S	17
9792 - 9793	18
9794 - 9796 - 9796 S	19
9795 - 9795 S - 9797 - 9797 S	20
5790 - 5791	21
5792	22

Cilindros / Cylinders / Cylindres 22**Testa Eléctrica 500** / Electric Safety Strike / Cerradero Eléctrico / Serrure Électrique

500 N. 501. 502. 503 - 504 A/B. 505 A/B. 506 A/B. 507 A/B	23
---	----

Chapas Testa Inox / Stainless Steel Striker Plates / Cerraderos en Acero Inoxidable /
Gâches en Acier Inoxydable

CT1 - CT2 - CT3 - CT4	24
5790 - 7791 - 7716 RG - 7791 RG - 5791 - 9792 - 9794 - 5793 - 5794 - 7792 - 7716 R - 7797 R - 9791	25
9793 - 9795 - 9797 - Central Alavanca - Ponta Alavanca - Trinqueta	26

Planos de Maquinação / Tooling Schemes / Planos de Maquinación / Plans de Machination

7615 - 7707 - 7709 - 7715	27
7717 - 7799 - 7716 - 7791 - 7791 S - 7795 - 7797 - 7798	28

Aviso / Notice / Avis 29

FECHADURAS MULTIPUNTO DE 3 PUNTOS

MULTIPOINT LOCKS 3 POINTS
 CERRADURAS MULTIPUNTO DE 3 PUNTOS
 SERRURES MULTIPONT 3 POINTS

7615

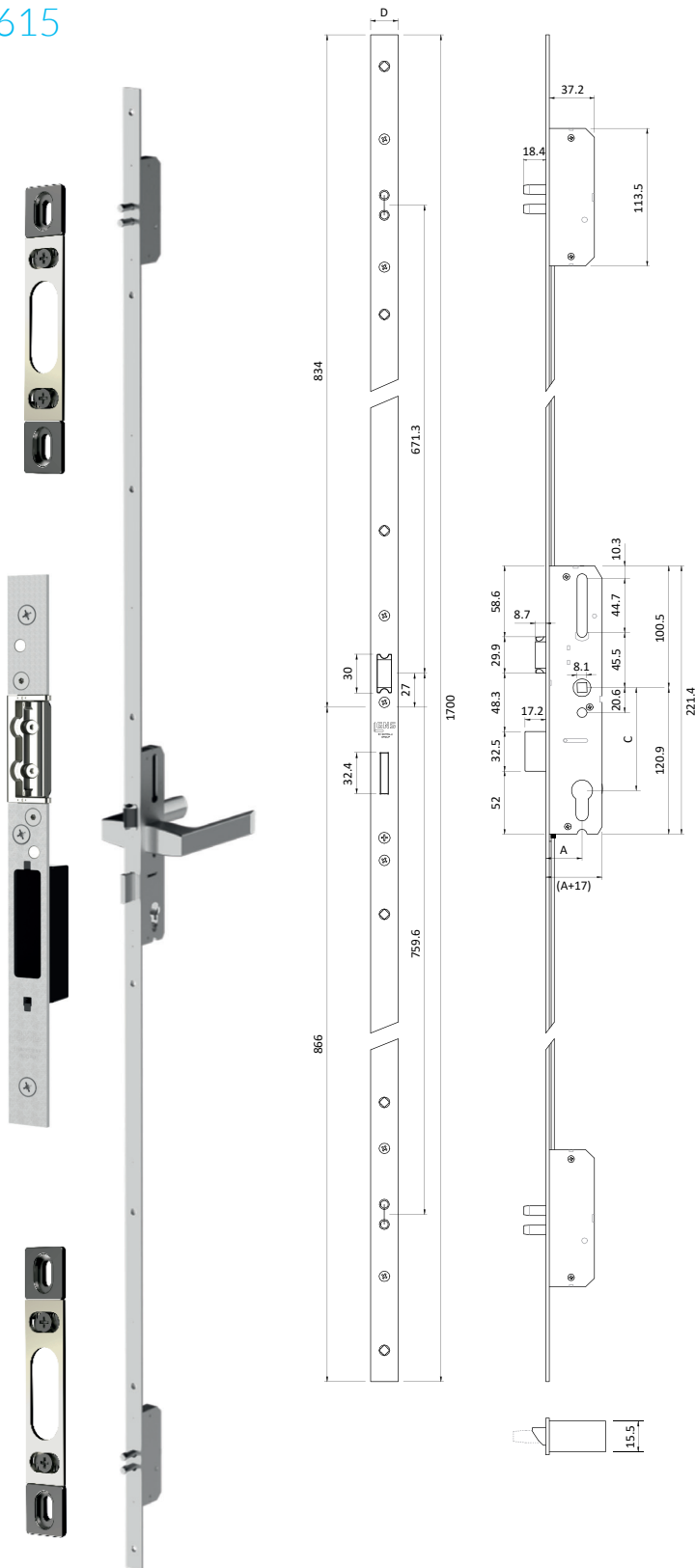

- › O sistema de movimento do fecho de engrenagens foi desenvolvido para proporcionar um fechamento robusto, suave e progressivo de todo o sistema. A fechadura de engrenagens alcançou uma classificação elevada em ensaios conduzidos por um laboratório independente. No mesmo teste, foi atribuída uma classificação de durabilidade, com a fechadura ultrapassando os 200 000 ciclos.
- › The gear locking system was developed to allow a robust, smooth, and progressive locking of the entire system. The gear action lock has achieved a high classification in tests conducted by an independent laboratory. In the same test, a durability classification was assigned, with the lock surpassing 200 000 cycles.
- › El sistema de movimiento del cierre de engranajes se desarrolló para permitir un cierre robusto, suave y progresivo de todo el sistema. La cerradura de engranajes ha alcanzado la categoría elevada en pruebas realizadas por un laboratorio independiente. En el mismo ensayo, se le asignó la clasificación de durabilidad, habiendo superado la cerradura los 200 000 ciclos.
- › Le système de mouvement du mécanisme de verrouillage à engrenages a été développé pour permettre une fermeture robuste, fluide et progressive de l'ensemble du système. La serrure à engrenage a atteint la catégorie d'utilisation intense lors d'essais réalisés en laboratoire indépendant. Au cours du même essai, le grade de durabilité lui a été attribué, la serrure ayant dépassé les 200 000 cycles.

A	C	D
30/35mm	85mm	16mm
		22mm
		24mm
		TU
92mm	85mm	16mm
		22mm
		24mm
		TU



FECHADURAS MULTIPUNTO DE 5 PONTOS

MULTIPOINT LOCKS 5 POINTS
CERRADURAS MULTIPUNTO DE 5 PUNTOS
SERRURES MULTIPONT 5 POINTS

- › Fechadura de 5 pontos para alumínio. Entrada de cilindro ou de chave em cruz, trinco com afinação e língua basculante. Testa em inox e chapas testa de afinação em inox. Testa lisa ou em "U".
- › 5 points lock for aluminium. Cylinder entrance or cross key, dead bolt reversible and adjustable latch. Stainless steel front and stainless steel striker plates. Flat shape / "U" shape.
- › Cerradura de 5 puntos para aluminio. Entrada de cilindro o llave en cruz, picaporte reversible y palanca basculante. Frente de acero inoxidable y cerraderos ajustables en acero inoxidable. Frente plano / en "U".
- › Serrure à 5 points pour aluminium. Entrée de cylindre ou clé en croix, demi-tour reversible et pêne basculant. Têtière plate en acier inoxydable et gâches réglage en acier inox. Têtière plate / en "U".

7706 / 7707

A	C	D
25mm*		
30mm	85/92mm	22/24mm
35mm		

* Só com caixa central de 20.

* Available only with 20mm box thickness.

* Solo disponible con caja espesor de 20.

* Disponible uniquement avec boîtier épaisseur 20mm.

7706



7707 R

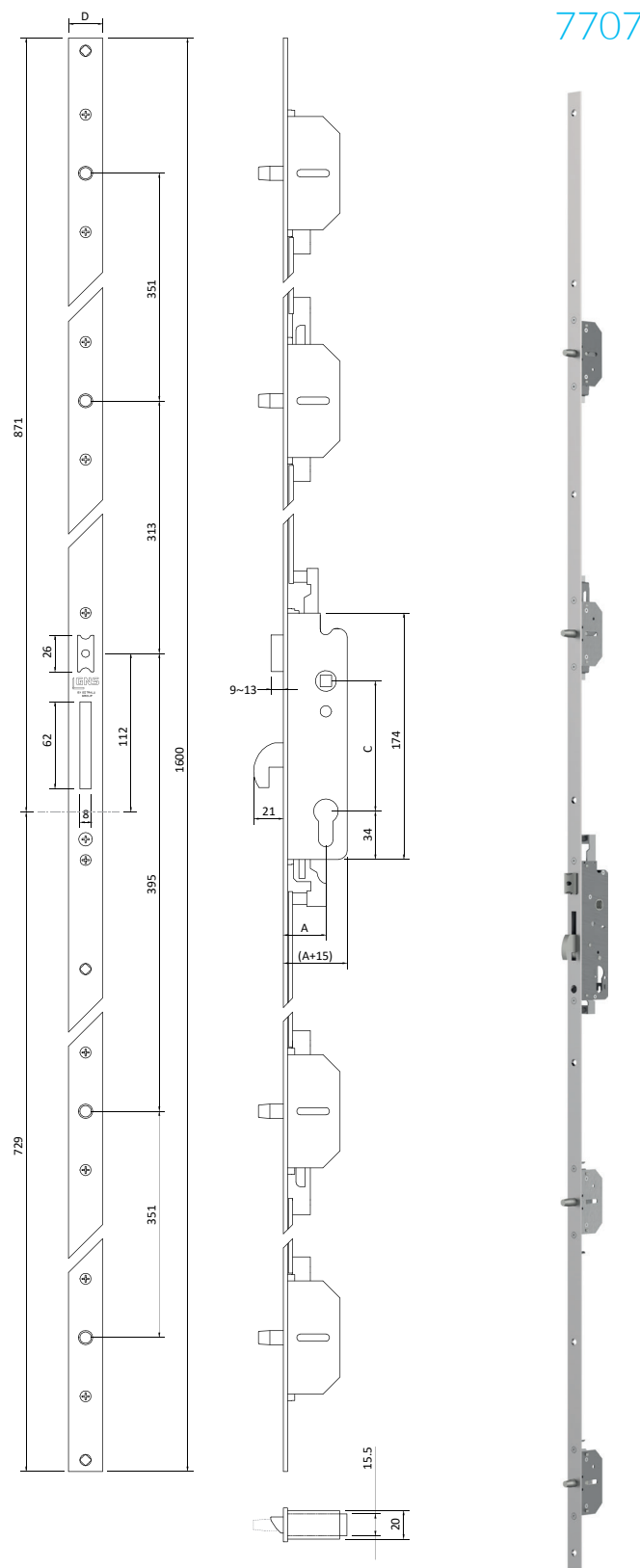

7707



FECHADURAS MULTIPUNTO DE 3 PONTOS

MULTIPOINT LOCKS 3 POINTS
 CERRADURAS MULTIPUNTO DE 3 PUNTOS
 SERRURES MULTIPONT 3 POINTS

7709

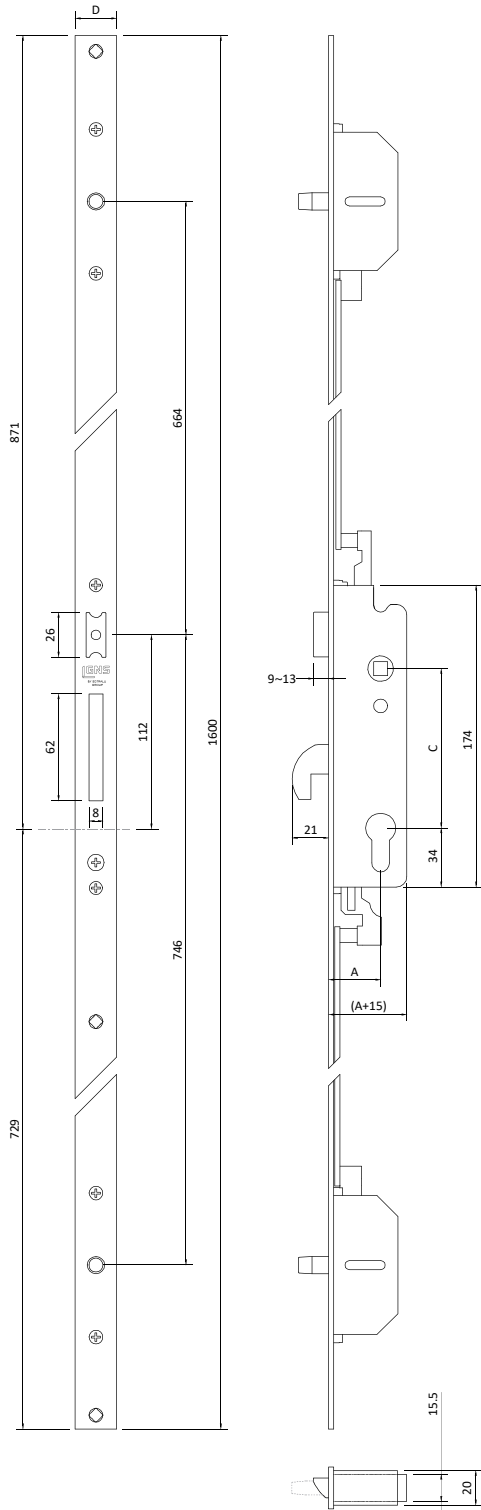

- › Fechadura de 3 pontos de fecho para alumínio com entrada de cilindro.
 Trinco de afinação e língua basculante central.
 Pontos de fecho superior e inferior em pistão rotativo de aço inox. Frente, chapas testa de afinação e reforços de dobradiça em aço inox.
 Frente plana ou em "U".
- › 3 points lock for aluminum with cylinder entrance.
 Dead bolt reversible and adjustable latch.
 Upper and lower locking points in stainless steel rotary pins. Front, adjustable striker plate and hinge reinforcements in stainless steel.
 Flat shape / "U" shape.
- › Cerradura de 3 puntos de cierre para aluminio con entrada de cilindro.
 Picaporte reversible y palanca basculante central.
 Puntos de cierre superior y inferior en pistón rotativo de acero inoxidable. Frente, cerraderos ajustables y refuerzos de bisagra en acero inoxidable.
 Frente plano / en "U".
- › Serrure à 3 points de fermeture pour aluminium avec entrée de cylindre.
 Demi-tour reversible et pêne basculant.
 Points de fermeture supérieur et inférieur en piston rotatif en acier inoxydable.
 Têtière plate, gâches réglage et renforcement de paumelles en acier inoxydable. Têtière plate / en "U".

7709 R



SLIMBOX
 CONCEPT

A	C	D
25mm*		
30mm	85/92mm	22/24mm
35mm		

- * Só com caixa central de 20.
- * Available only with 20mm box thickness.
- * Solo disponible con caja espesor de 20.
- * Disponible uniquement avec boîtier épaisseur 20mm.



FECHADURAS MULTIPUNTO DE 3 PONTOS

MULTIPOINT LOCKS 3 POINTS
 CERRADURAS MULTIPUNTO DE 3 PUNTOS
 SERRURES MULTIPONT 3 POINTS

- › Fechadura de 3 pontos para alumínio. Entrada de cilindro, trinco de afinação, língua basculante central e pitons rotativos com inox nas extremidades. Testa, chapas testa de afinação e reforços de dobradiça em aço inox. Testada em câmara salina para valores superiores a 600 horas. Espessura da caixa 15,5mm.
- › 3 points lock for aluminum. Cylinder entrance, dead bolt reversible, adjustable latch and rotating pins with stainless steel at the ends. Stainless steel front, adjustable striker plate, and hinge reinforcements. Tested in saline chamber for values exceeding 600 hours. Slim box line with 15,5mm.
- › Cerradura de 3 puntos para aluminio. Entrada de cilindro, picaporte reversible, palanca basculante central y pitones rotativos con acero inoxidable en los extremos. Frente, cerraderos ajustables y refuerzos de bisagra en acero inoxidable. Testada en cámara salina para valores superiores a 600 horas. Grosor de la caja 15,5mm.
- › Serrure à 3 points pour aluminium. Entrée de cylindre, demi-tour reversible, pêne central basculant et pistons rotatifs en acier inoxydable aux extrémités. Têtière plate, gâches réglage et renforcement de paumelles en acier inoxydable. Testée en chambre saline pour des valeurs supérieures à 600 heures. Slim box avec 15,5mm.

7715

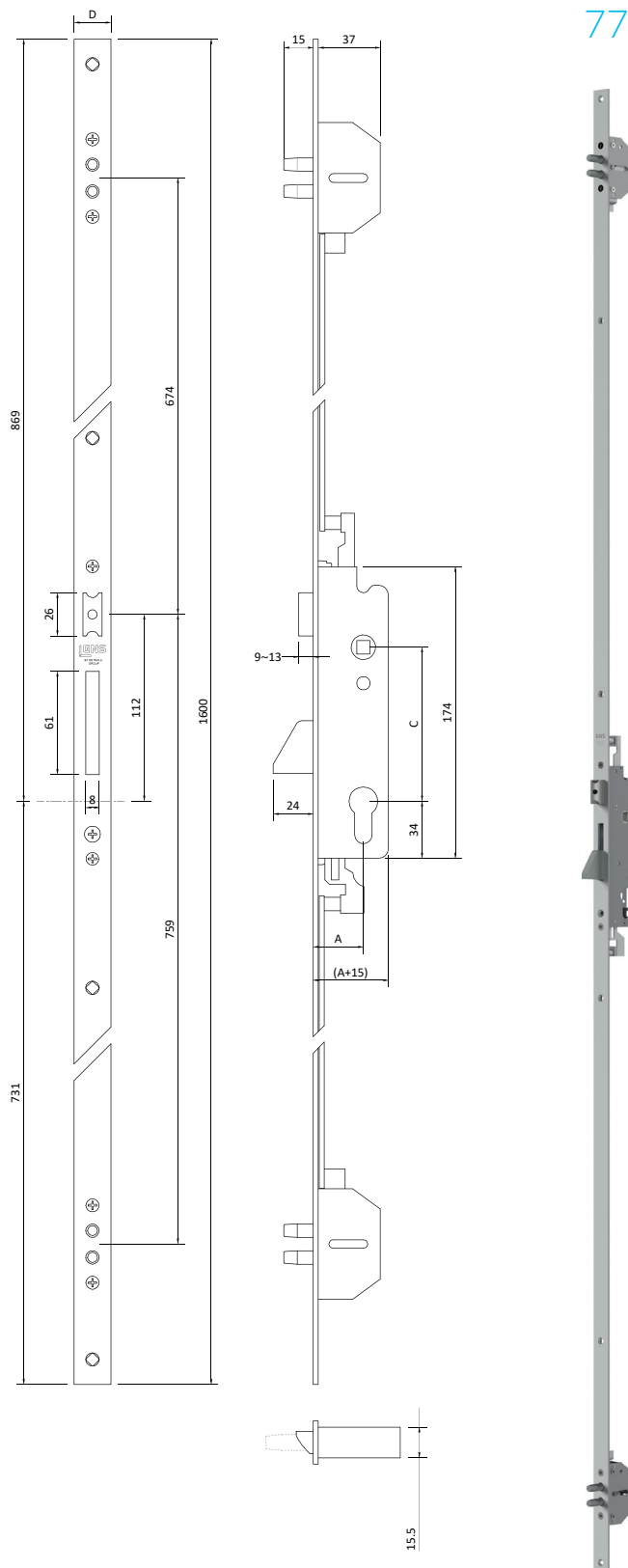

7715 R



SLIMBOX
 CONCEPT

A	C	D
25mm		
30mm	85/92mm	22/24mm
35mm		



FECHADURAS MULTIPUNTO DE 3 PUNTOS

MULTIPOINT LOCKS 3 POINTS
CERRADURAS MULTIPUNTO DE 3 PUNTOS
SERRURES MULTIPONT 3 POINTS

7715 ALU

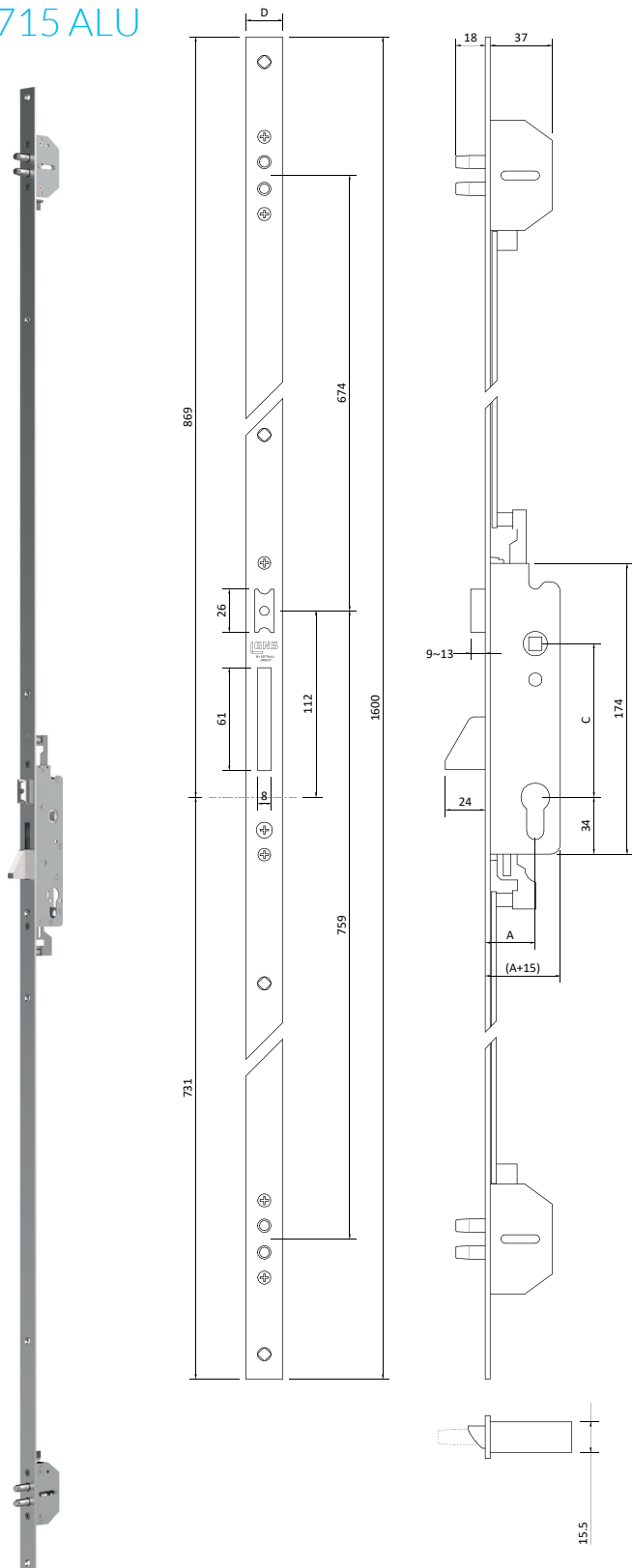

- › Fechadura de 3 pontos de fecho em alumínio.
Testada para um milhão de ciclos.
Molas em aço inox. Testa em alumínio endurecido anodizado natural, caixa zincada.
Lubrificação base lítio. Mais silenciosa e mais leve.
Força de fecho 3 vezes superior. Testada em câmara salina para valores superiores a 600 horas.
- › 3 points lock for aluminum.
Tested for one million cycles.
Stainless steel springs. Natural anodized hardened aluminum front plate, zinc plate backset.
Lithium based lubrication. Quieter and lighter.
Closing force 3 times greater.
Tested in saline chamber for values to 600 hours.
- › Cerradura de 3 puntos de cierre en aluminio.
Testada para un millón de ciclos.
Muelles en acero inoxidable. Frente en aluminio endurecido anodizado natural, caja zincada.
Lubricación base litio. Más silencioso y más leve.
Fuerza de cierre 3 veces superior. Testada en cámara salina para valores superiores a 600 horas.
- › Serrure à 3 points de fermeture en aluminium.
Testée à un million de cycles.
Ressorts en acier inoxydable. Têtière en aluminium durci anodisée naturel, boîtier zingué.
Lubrification base lithium. Plus silencieuse et plus doux. Force de fermeture 3 fois supérieur. Testée en chambre saline pour des valeurs supérieurs à 600 heures.

SLIMBOX
CONCEPT

A	C	D
30mm	85/92mm	22mm
35mm		



FECHADURAS MULTIPUNTO DE 3 PONTOS

MULTIPOINT LOCKS 3 POINTS
CERRADURAS MULTIPUNTO DE 3 PUNTOS
SERRURES MULTIPONT 3 POINTS

- › Fechadura de 3 pontos para alumínio. Entrada de cilindro, trinco com afinação e língua basculante. Testa em inox e chapas testa de afinação em inox. Testa lisa ou em "U".
- › 3 points lock for aluminium. Cylinder entrance, dead bolt reversible and adjustable latch. Stainless steel front and stainless steel striker plates. Flat shape / "U" shape.
- › Cerradura de 3 puntos para aluminio. Entrada de cilindro, picaporte reversible y palanca basculante. Frente de acero inoxidable y cerraderos ajustables en acero inoxidable. Frente plano / en "U".
- › Serrure à 3 points pour aluminium. Entrée de cylindre, demi-tour reversible et pêne basculant. Têtière plate en acier inoxydable et gâches réglage en acier inoxydable. Têtière plate / en "U".

7717 R



SLIMBOX
CONCEPT

A	C	D
30mm	85/92mm	22/24mm
35mm		

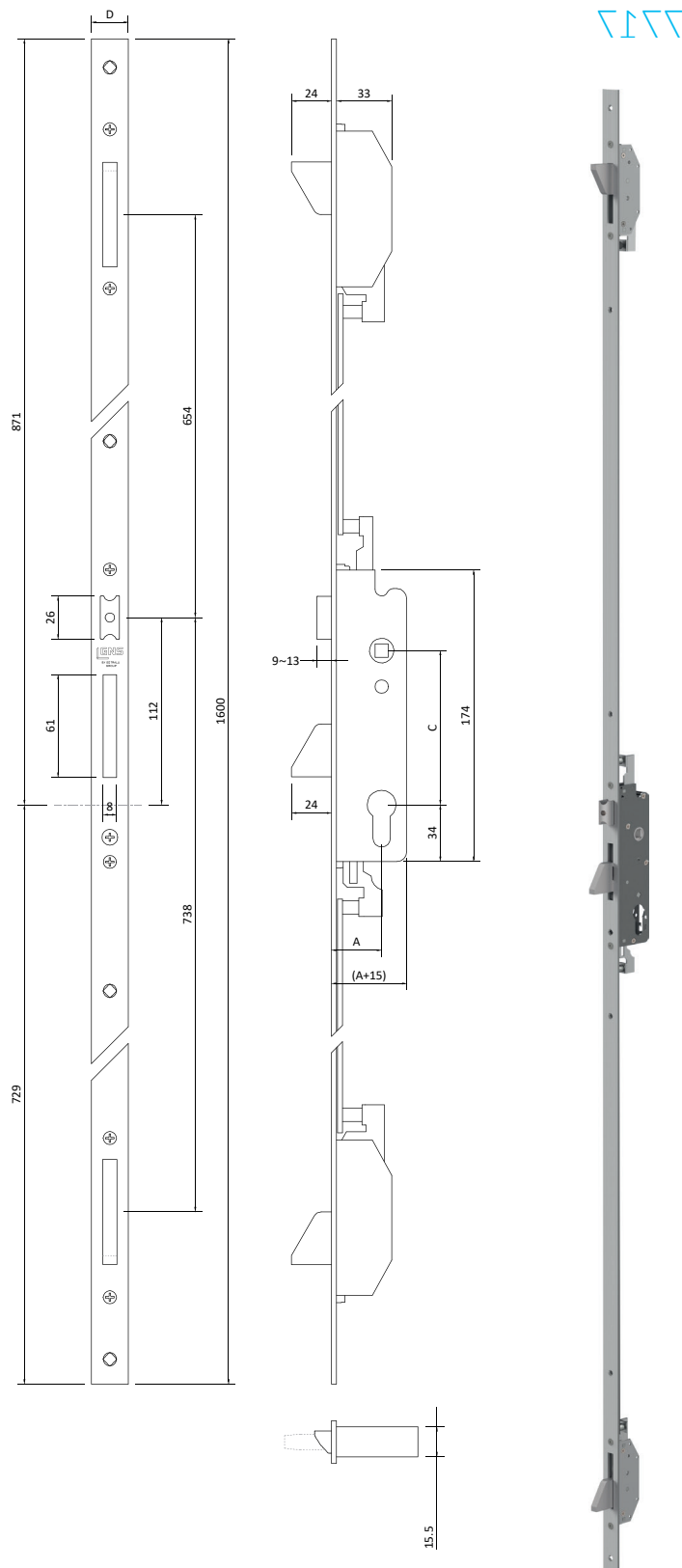

FECHADURAS MULTIPUNTO DE 3 PUNTOS

MULTIPOINT LOCKS 3 POINTS
 CERRADURAS MULTIPUNTO DE 3 PUNTOS
 SERRURES MULTIPONT 3 POINTS

7799 / 7799 A

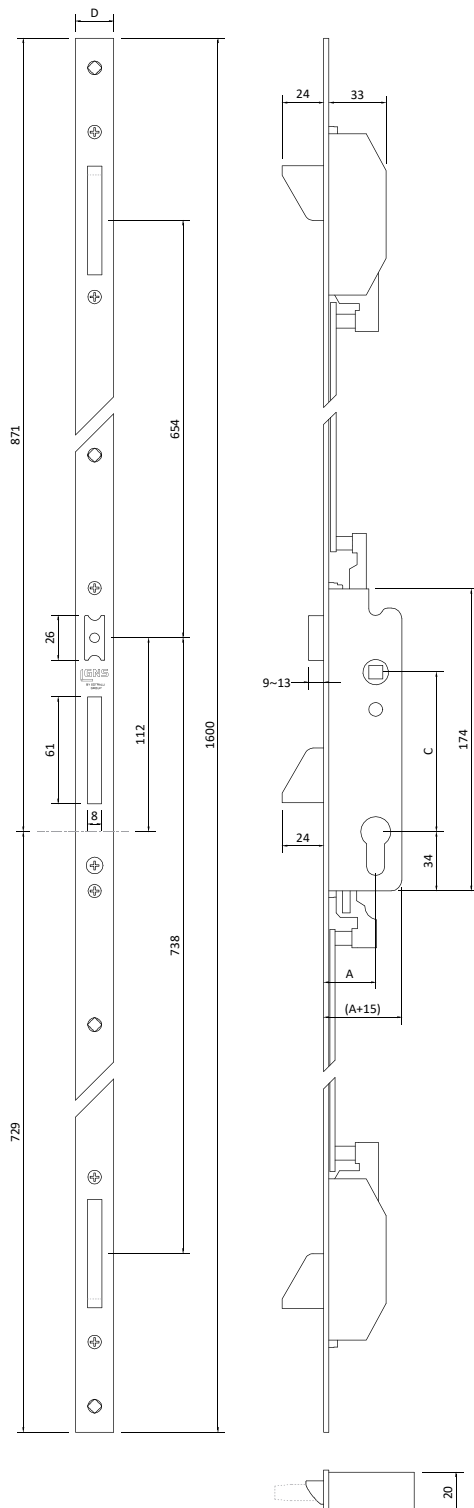

- › Fechadura de 3 pontos para alumínio. Entrada de cilindro, trinco com afinação e língua basculante. Testa em inox e chapas testa de afinação em inox. Testa lisa ou em "U".
- › 3 points lock for aluminium. Cylinder entrance, dead bolt reversible and adjustable latch. Stainless steel front and stainless steel striker plates. Flat shape / "U" shape.
- › Cerradura de 3 puntos para aluminio. Entrada de cilindro, picaporte reversible y palanca basculante. Frente de acero inoxidable y cerraderos ajustables en acero inoxidable. Frente plano / en "U".
- › Serrure à 3 points pour aluminium. Entrée de cylindre, demi-tour reversible et pêne basculant. Têtière plate en acier inoxydable et gâches réglage en acier inoxydable. Têtière plate / en "U".

7799 R



A	C	D
25mm	85/92mm	22/24mm



7799 A 7799

FECHADURAS MULTIPUNTO DE 3 PUNTOS

MULTIPOINT LOCKS 3 POINTS
 CERRADURAS MULTIPUNTO DE 3 PUNTOS
 SERRURES MULTIPONT 3 POINTS

7796 / 7796 A



7799 G

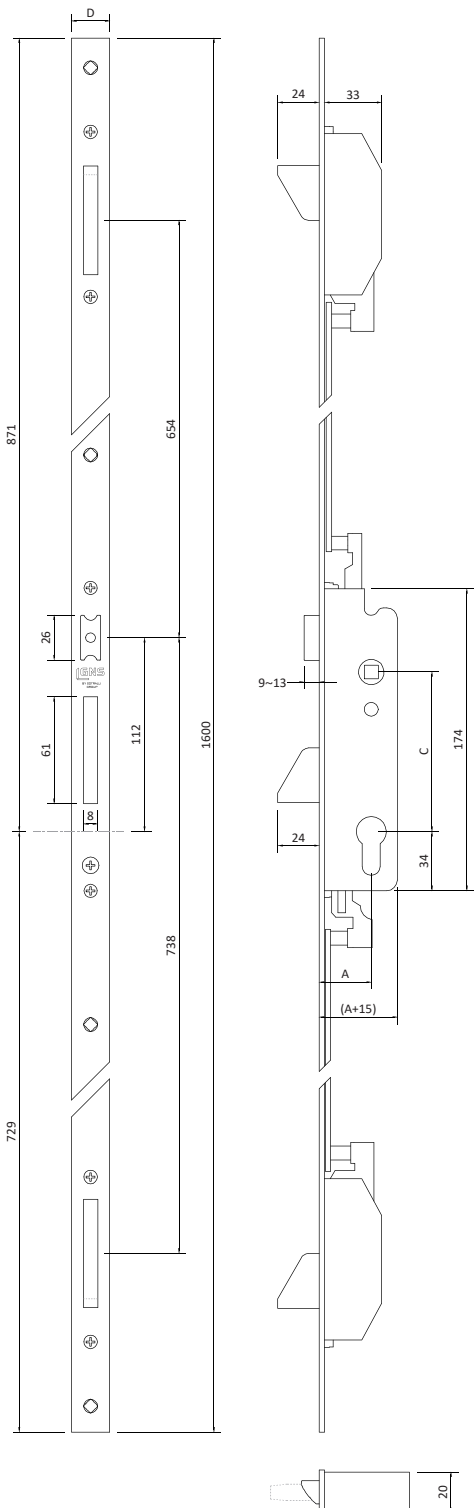
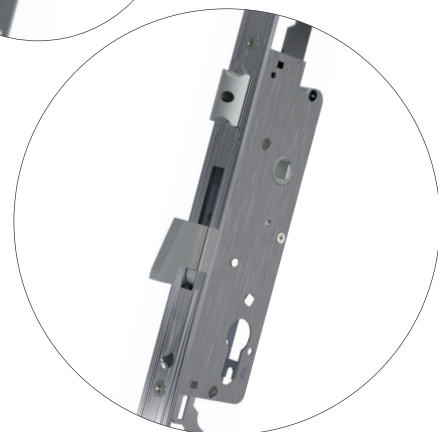

A	C	D
25mm	85/92mm	22/24mm
30mm		
35mm		



7799 G

7796 A

7796

FECHADURAS DE 1 PONTO

1 POINT LOCKS
CERRADURAS DE 1 PUNTO
SERRURES À 1 POINT

7716

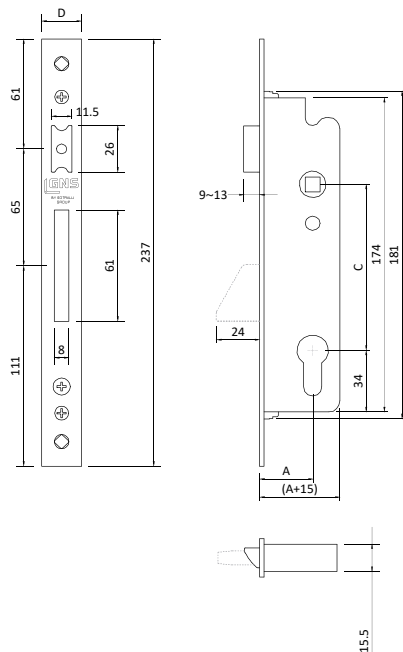

- › Fechadura de prumo para alumínio, trinco com afinação e língua basculante, com entrada de cilindro. Testa e chapa testa em inox. Espessura da caixa 15,5mm.
- › Monopoint lock for aluminum, dead bolt reversible and adjustable latch, with cylinder entrance. Stainless steel front and adjustable striker plate. Slim box line with 15,5mm.
- › Cerradura de 1 punto para aluminio, picaporte reversible y palanca basculante, con entrada de cilindro. Frente y cerradero ajustable en acero inoxidable. Grosor de la caja 15,5mm.
- › Serrure à 1 point pour aluminium, demi-tour reversible et pêne basculant, avec entrée de cylindre. Têtière plate et gâche réglage en acier inoxydable. Slim box avec 15,5mm.

7716 R



SLIMBOX
CONCEPT

A	C	D
25mm	85/92mm	22mm
30mm		
35mm		



FECHADURAS DE 1 PONTO

1 POINT LOCKS
CERRADURAS DE 1 PUNTO
SERRURES À 1 POINT

7716 G



7716 L



7716 R



7716 SG



7716 T



FECHADURAS DE 1 PONTO

1 POINT LOCKS
CERRADURAS DE 1 PUNTO
SERRURES À 1 POINT

7791/7791 A

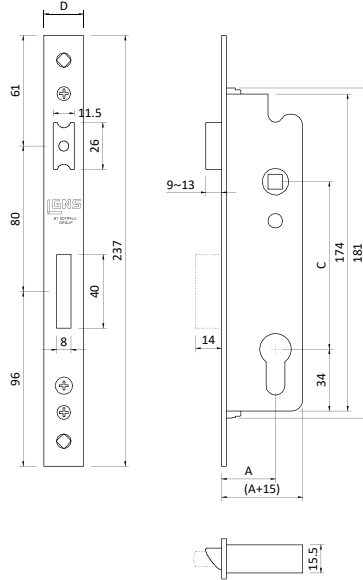

- › Fechadura de prumo para alumínio, testa em inox com entrada de cilindro e de chave em cruz, trinco de fácil inversão e língua de correr.
- › Monopoint lock for aluminum, stainless steel front with cylinder entrance and cross key, dead bolt reversible and advancing bolt.
- › Cerradura de 1 punto para aluminio, frente de acero inoxidable con entrada de cilindro y llave en cruz, picaporte reversible accionado por manilla o llave y palanca deslizante.
- › Serrure à 1 point pour aluminium, tête plate en inoxydable avec entrée de cylindre et clé en croix, demi-tour reversible et pêne coulissant.

7791 S

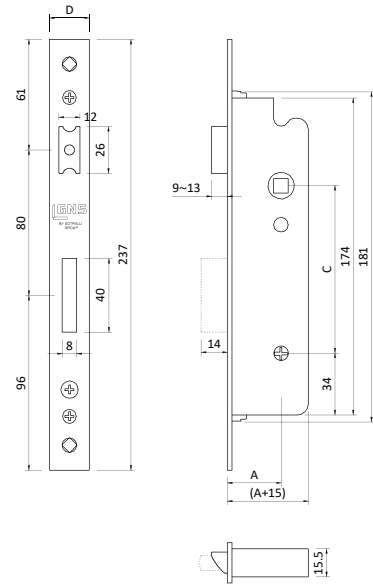

7792

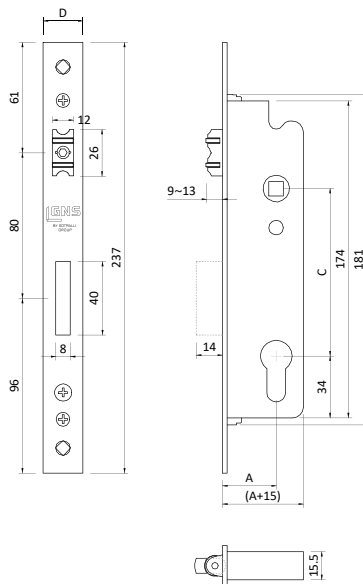

SLIMBOX
CONCEPT

A	C	D
20mm		
23mm		
25mm	85/92mm	22/24mm
30mm		
35mm		

- * 20, 23 não disponível em chave de cruz.
- * 20, 23 unavailable in cross key.
- * 20, 23 no disponible en llave de seguridad.
- * 20, 23 indisponible clé croix.



7791 S

7791 A

7791

FECHADURAS DE 1 PONTO

1 POINT LOCKS
CERRADURAS DE 1 PUNTO
SERRURES À 1 POINT

- › Fechadura de prumo para alumínio, trinco com afinação e língua basculante com entrada de chave em cruz. Testa e chapa testa de afinação em inox.
- › Monopoint lock for aluminum, dead bolt reversible and adjustable latch with cross key. Stainless steel front and adjustable striker plate.
- › Cerradura de 1 punto para aluminio, picaporte reversible y palanca basculante con llave en cruz. Frente y cerradero ajustable en acero inoxidable.
- › Serrure à 1 point pour aluminium, demi-tour reversible et pêne basculant avec clé en croix. Têtière plate et gâche réglage en acier inoxydable.

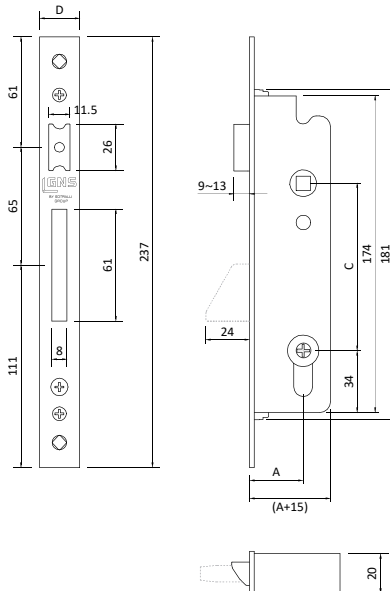

7794 / 7794 A



7794 R



A	C	D
25mm		
30mm	85/92mm	22/24mm
35mm		



7794 A 7794

FECHADURAS DE 1 PONTO

1 POINT LOCKS
CERRADURAS DE 1 PUNTO
SERRURES À 1 POINT

7795

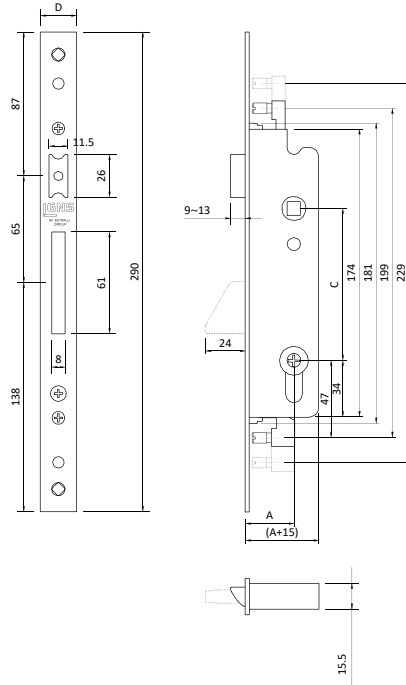

- › Fechadura de prumo para alumínio, trinco com afinação e língua basculante com entrada de cilindro e de chave em cruz. Testa e chapa testa de afinação em inox.
- › Monopoint lock for aluminum, dead bolt reversible and adjustable latch with cylinder entrance and cross key. Stainless steel front and adjustable striker plate.
- › Cerradura de 1 punto para aluminio, picaporte reversible y palanca basculante con entrada de cilindro y llave en cruz. Frente y cerradero ajustable en acero inoxidable.
- › Serrure à 1 point pour aluminium, demi-tour reversible et pêne basculant, avec entrée de cylindre et clé en croix. Têtière plate et gâche réglage en acier inoxydable.

7795 R / 7798 R



7798

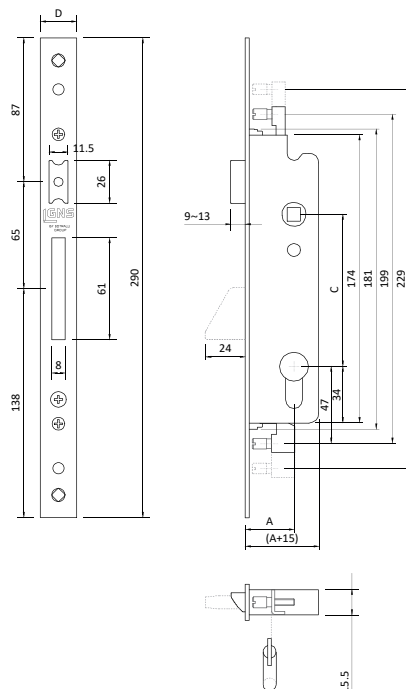

SLIMBOX
CONCEPT

A	C	D
25mm	85/92mm	22/24mm
30mm		
35mm		



FECHADURAS DE 1 PONTO

1 POINT LOCKS
CERRADURAS DE 1 PUNTO
SERRURES À 1 POINT

- › Fechadura para alumínio, testa em inox com entrada de cilindro e língua de correr.
- › Lock for aluminum, stainless steel front with cylinder entrance and advancing bolt.
- › Cerradura para aluminio, frente de acero inoxidable con entrada de cilindro y palanca deslizante.
- › Serrure pour aluminium, tête en acier inoxydable avec entrée de cylindre et pêne coulissant.

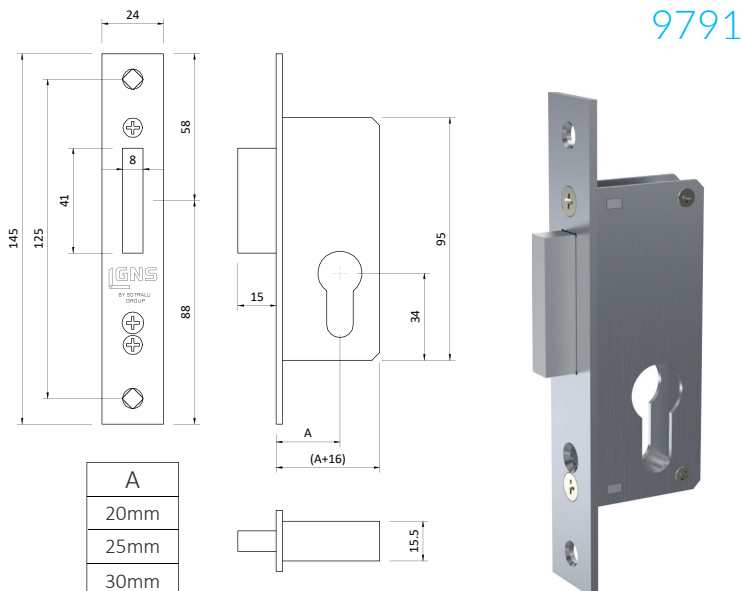

- › Fechadura para alumínio, testa em inox com entrada de chave em cruz e língua de correr.
- › Lock for aluminum, stainless steel front with cross key and advancing bolt.
- › Cerradura para aluminio, frente de acero inoxidable con entrada de llave en cruz y palanca deslizante.
- › Serrure pour aluminium, tête en acier inoxydable avec entrée de clé en croix et pêne coulissant.

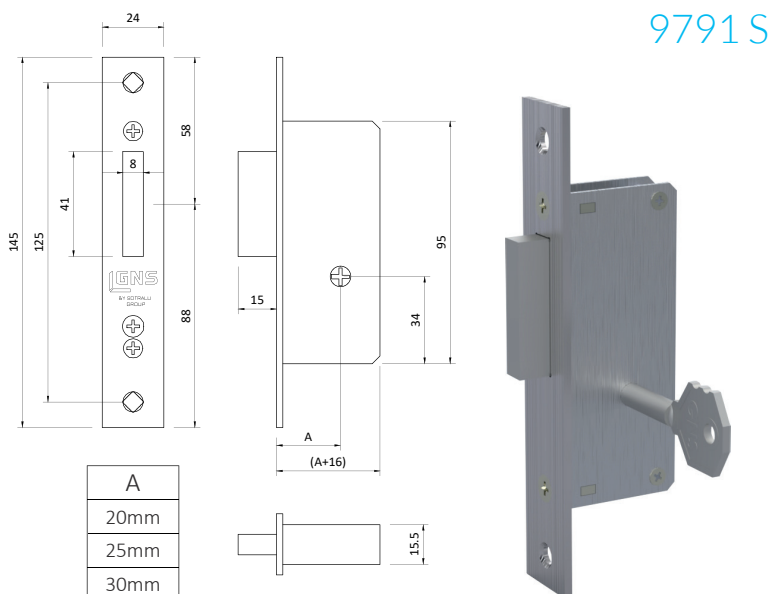

FECHADURAS DE 1 PONTO

1 POINT LOCKS
CERRADURAS DE 1 PUNTO
SERRURES À 1 POINT

9793

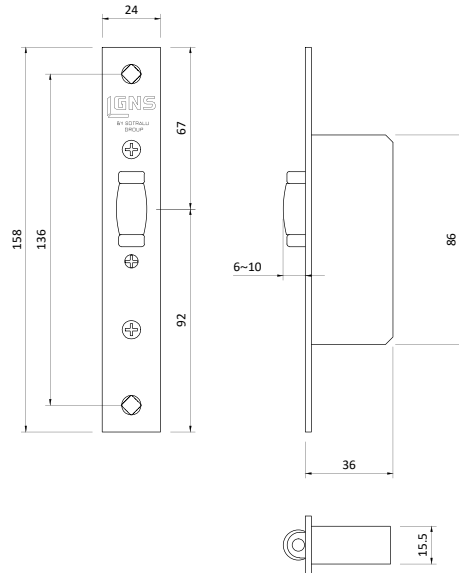

- › Fechadura para alumínio, testa em inox com rolete.
- › Lock for aluminium, stainless steel front with roller latch.
- › Cerradura para aluminio, frente de acero inoxidable con rodillo.
- › Serrure pour aluminium, tête plate en acier inoxydable avec rouleau.

9794

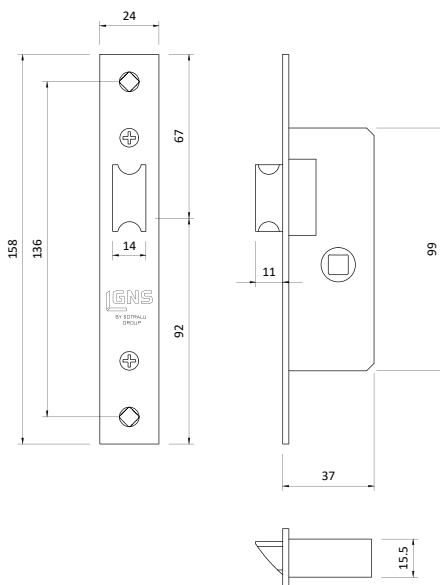

- › Fechadura para alumínio, testa em inox com trinco.
- › Lock for aluminium, stainless steel front with latch.
- › Cerradura para aluminio, frente de acero inoxidable con picaporte.
- › Serrure pour aluminium, tête plate en acier inoxydable avec demi-tour.



FECHADURAS DE 1 PONTO

1 POINT LOCKS
CERRADURAS DE 1 PUNTO
SERRURES À 1 POINT

- › Fechadura para alumínio, testa em inox com entrada de cilindro, gancho e espigão.
- › Lock for aluminium, stainless steel front with cylinder entrance, hook and bolt.
- › Cerradura para aluminio, frente de acero inoxidable con entrada para cilindro, gancho y espigón.
- › Serrure pour aluminium, tête plate en acier inoxydable avec entrée de cylindre, crochet et pêne dormant.

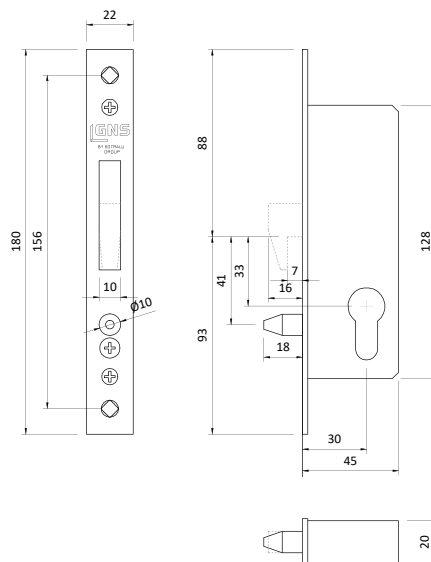

9796



- › Fechadura para alumínio, testa em inox com entrada de chave em cruz, gancho e espigão.
- › Lock for aluminium, stainless steel front with cross key, hook and bolt.
- › Cerradura para aluminio, frente de acero inoxidable con entrada de llave de seguridad, gancho y espigón.
- › Serrure pour aluminium, tête plate en acier inoxydable avec entrée de clé en croix, crochet et pêne dormant.

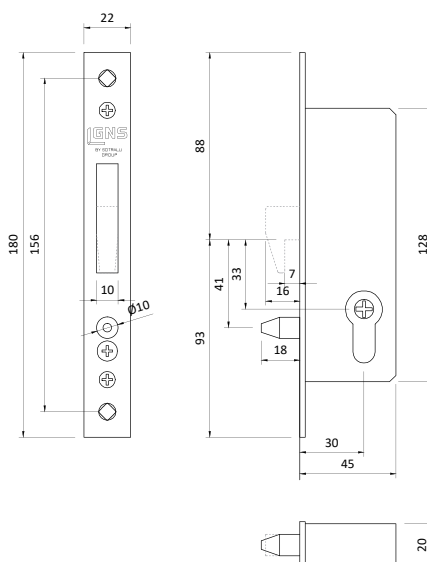

9796S



FECHADURAS DE 1 PONTO

1 POINT LOCKS
CERRADURAS DE 1 PUNTO
SERRURES À 1 POINT

9795 S

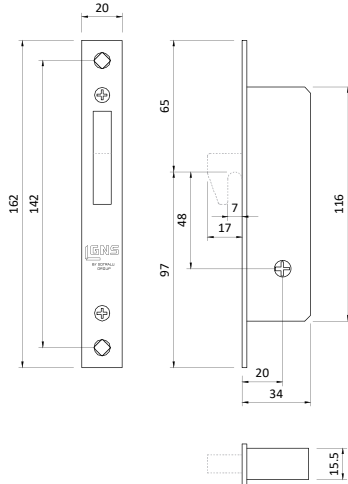

- › Fechadura de prumo para alumínio, língua de gancho e língua basculante, com entrada de cilindro e de chave em cruz. Testa e chapa testa em inox.
- › Monopoint lock for aluminum, hook and adjustable latch, with cylinder entrance and cross key. Stainless steel front and adjustable striker plate.
- › Cerradura de 1 punto para aluminio, palanca de gancho y palanca basculante con entrada de cilindro y llave en cruz. Frente y cerradero ajustable de acero inoxidable.
- › Serrure 1 point pour aluminium, pêne crochet et pêne basculant, avec entrée de cylindre et clé en croix. Têtière plate et gâche réglage en acier inoxydable.

9797

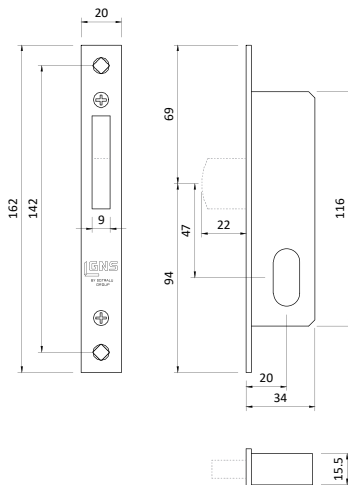

9795

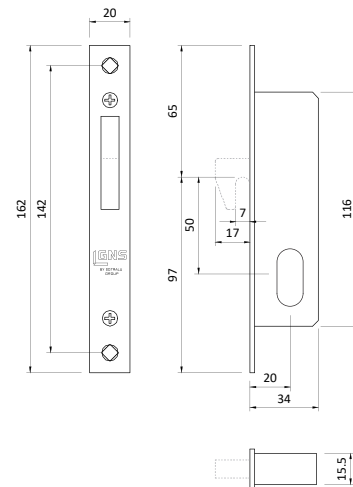

9797 S

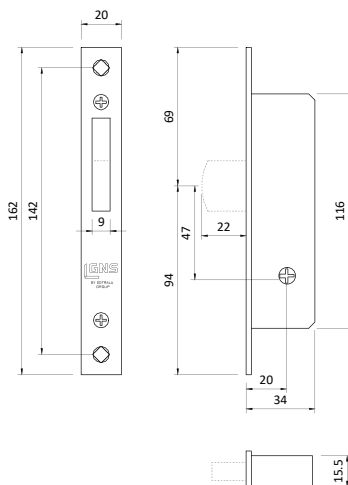

* Incluem Cilindro.
* Incluyen Cilindro.
* Includes Cylinder.
* Comprend Cilindre.

FECHADURAS DE 1 PONTO

1 POINT LOCKS
CERRADURAS DE 1 PUNTO
SERRURES À 1 POINT

- › Fechadura de almofada para alumínio, testa e chapa testa em alumínio, cilindro oval, espelhos em nylon e caixa zincor.
- › Mortise lock for aluminium, front and striker plate, oval cylinder, nylon locks shield and zinc plated body.
- › Cerradura de pano para aluminio, frente y cerradero ajustable de aluminio, cilindro ovalado, escudetes de nylon y caja de zincor.
- › Serrure à mortaiser pour aluminium, tête plate et gâche réglage en aluminium, cylindre oval, rosaces en nylon et boîtier en acier zincor.

5790

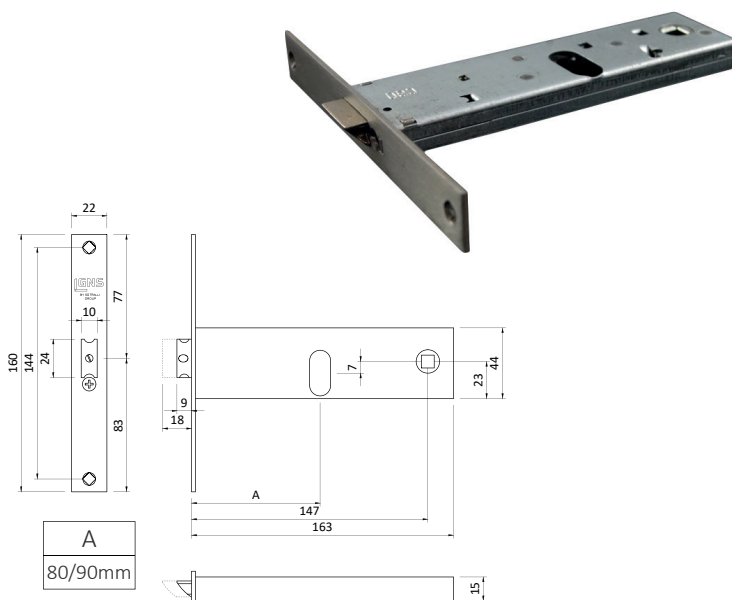

- › Fechadura de almofada para alumínio, testa e chapa testa em alumínio, cilindro oval, espelhos em nylon e caixa zincor. Entrada para euro cilindro.
- › Mortise lock for aluminium, front and striker plate, oval cylinder, nylon locks shield and zinc plated body. Entry for euro cylinder.
- › Cerradura de pano para aluminio, frente y cerradero ajustable de aluminio, cilindro ovalado, escudetes de nylon y caja de zincor. Entrada para euro cilindro.
- › Serrure à mortaiser pour aluminium, tête plate et gâche réglage en aluminium, cylindre oval, rosaces en nylon et boîtier en acier zincor. Entrée pour cylindre euro.

5791

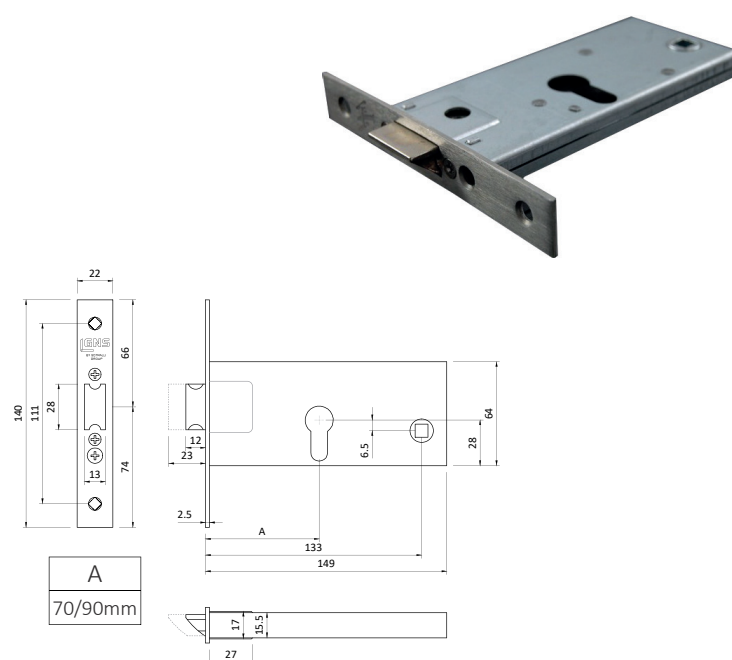

5790



5791



INOX



70



80



90



22

FECHADURAS DE 1 PONTO

1 POINT LOCKS
CERRADURAS DE 1 PUNTO
SERRURES À 1 POINT

5792

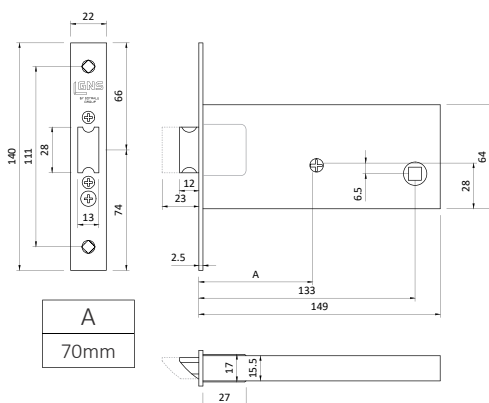

- › Fechadura de almofada para alumínio, testa em inox com entrada de chave em cruz.
- › Mortise lock for aluminium, stainless steel front with cross key.
- › Cerradura de pano para aluminio, frente de acero inoxidable con entada de llave en cruz.
- › Serrure à mortaiser pour aluminium, tête plate en acier inoxydable avec entrée de clé en croix.

CILINDROS

CYLINDERS
CYLINDRES



30 x 30
30 x 35
30 x 40
30 x 50

- › Cilindro com 3 chaves normais em latão niquelado.
- › Nickel brass with 3 standard keys cylinder.
- › Cilindro con 3 llaves normales en latón niquelado.
- › Cylindre avec 3 clés normales en laiton nickelé.



30 x 30
30 x 40
30 x 50
30 x 60

- › Cilindro de segurança em latão com 5 chaves de ponto em alpaca niquelada.
- › Nickel brass cylinder with 5 safety keys in nickel plated alpaca.
- › Cilindro de seguridad en latón con 5 llaves de punto en alpaca niquelada.
- › Cylindre de sécurité en laiton avec 5 clés à point en alpaca nickelé.



TESTA ELÉTRICA 500

ELETRIC SAFETY STRIKE
CERRADERO ELÉTRICO
SERRURE ÉLECTRIQUE

NUOVA 500

500 N. 501. 502. 503



- › Testa elétrica para fechaduras de embutir.
Frente em inox.
Fácil conversão de posição direita / esquerda.
- › Electrical striker for security locks.
Stainless steel front. Easy right / left conversion.
- › Cerradero eléctrico para cerraduras de embutir.
Frente de acero inoxidable.
Fácil conversión de posición derecha / izquierda.
- › Gâche électrique pour serrures de sécurité.
Têtière plate en acier inoxydable.
Conversion gauche / droite très facile.

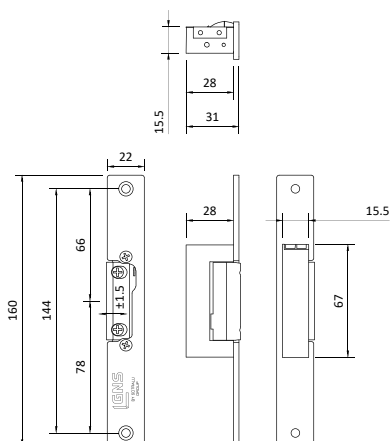

	Testa - Striker - Cerradero - Serrure			
	A	B	C	D
500 N	X		X	
501	X		X	X
502	X			
503	X			X
504		X	X	
505		X	X	X
506		X		
507		X		X

A: Normal / Normale
B: Grande / Big / Grand
C: Travão / Brake / Freno / Frein
D: Memória / Memory / Memoria / Mémoire

INSTALAÇÃO / APPLICATION

20m S = 0.5mm²
50m S = 1.0mm²

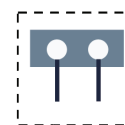

INPUT
8 - 12 DC/AC
1.2 - 1.5 A
Max. 10 VA (35sg)

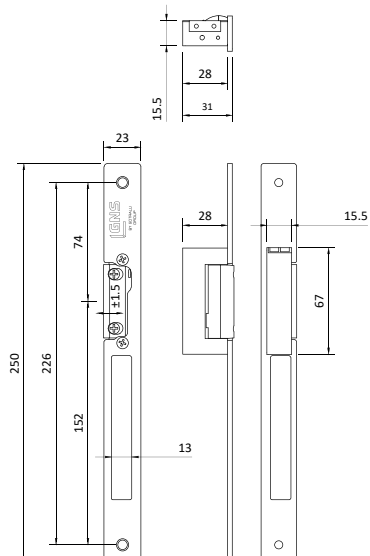

504 A / B. 505 A / B. 506 A / B. 507 A / B

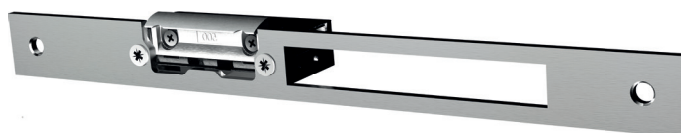

500N/504

CHAPAS TESTA INOX

STAINLESS STEEL STRIKER PLATES
 CERRADEROS EN ACERO INOXIDABLE
 GÂCHES EN ACIER INOXYDABLE

CT1



CT2



CT3



CT4



- › Chapa testa em inox com afinação.
- › Stainless steel adjustable striker plates.
- › Cerraderos en acero inoxidable afinación.
- › Gâches réglage en acier inoxydable.

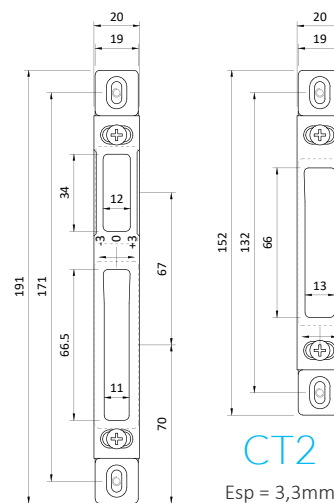

CT1
Esp = 3,3mm

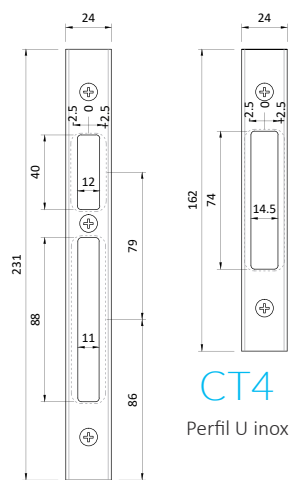

CT3
Perfil U inox



CHAPAS TESTA INOX

STAINLESS STEEL STRIKER PLATES
 CERRADEROS EN ACERO INOXIDABLE
 GÂCHES EN ACIER INOXYDABLE

5790

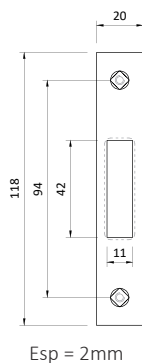

5791
 9792
 9794

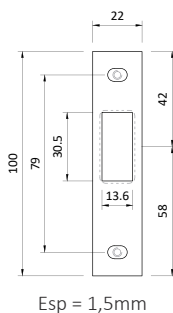

7716 R
 7797 R

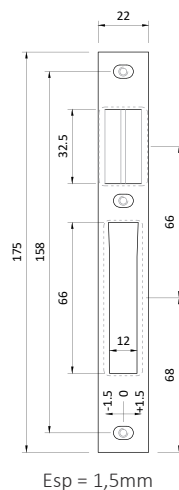

7716 RG
 7797 RG

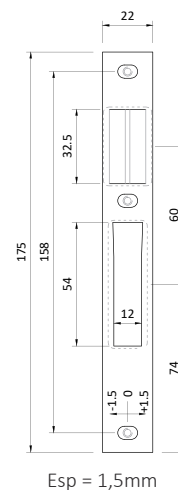

7791

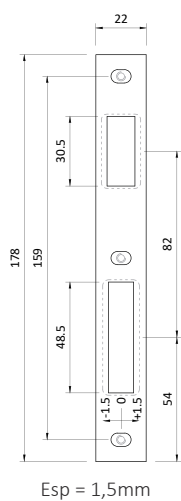

7792

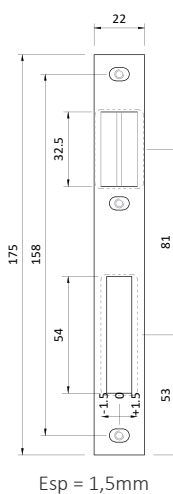

9791

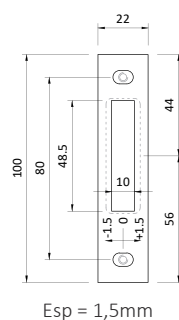

9793

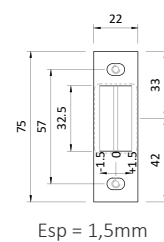

CHAPAS TESTA INOX

STAINLESS STEEL STRIKER PLATES
CERRADEROS EN ACERO INOXIDABLE
GÂCHES EN ACIER INOXYDABLE

9795
9797

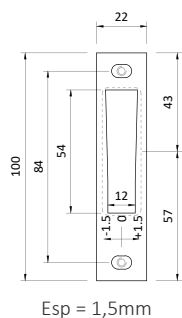

9796

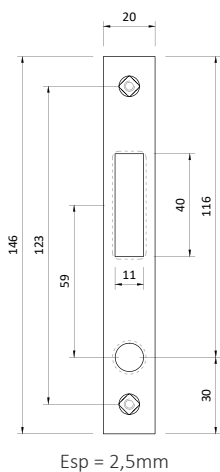

Central
Alavanca

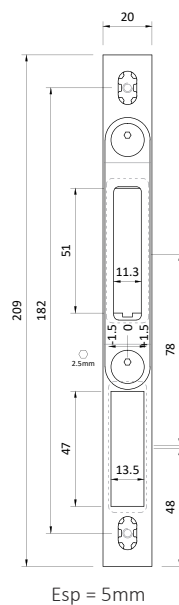

Ponta
Alavnca

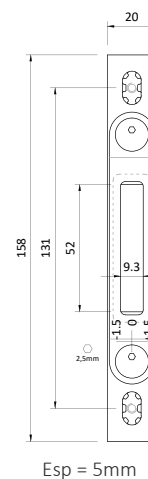

Trinqueta

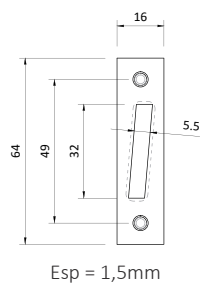

PLANOS DE MAQUINAÇÃO

TOOLING SCHEMES
 PLANOS DE MAQUINACIÓN
 PLANS DE MACHINATION

7615

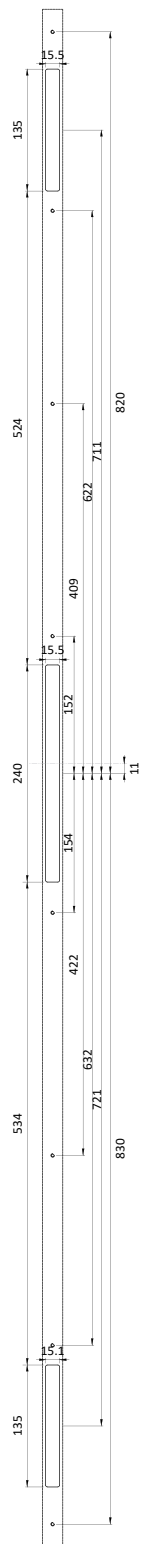

7707

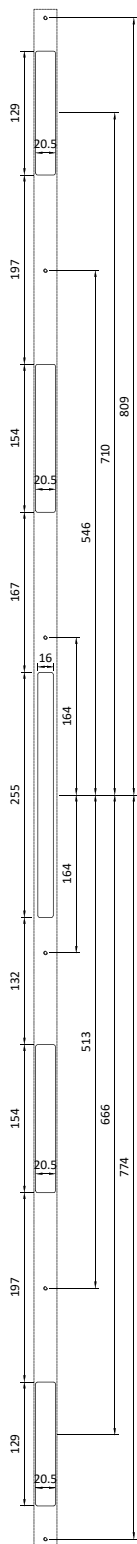

7709

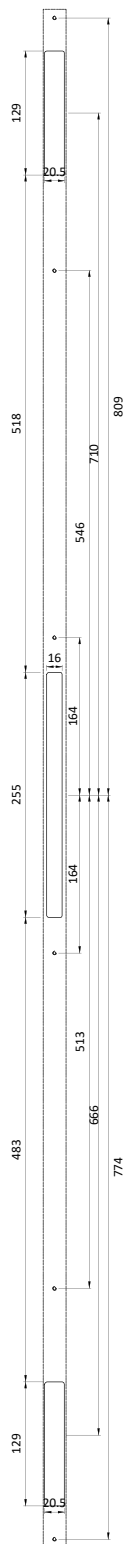

7715

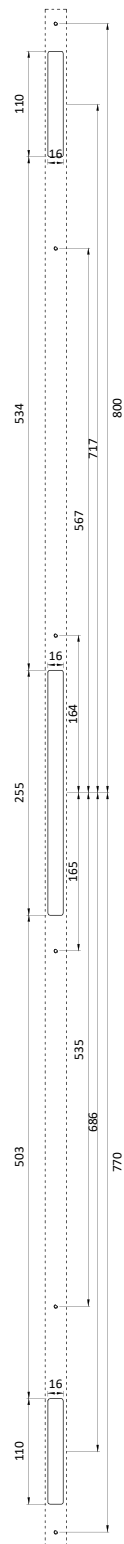

PLANOS DE MAQUINAÇÃO

TOOLING SCHEMES
PLANOS DE MAQUINACIÓN
PLANS DE MACHINATION

7717

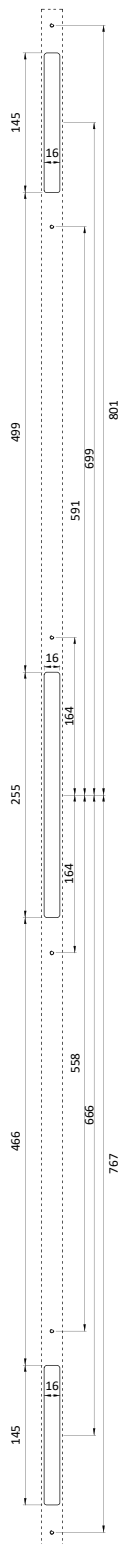

7799

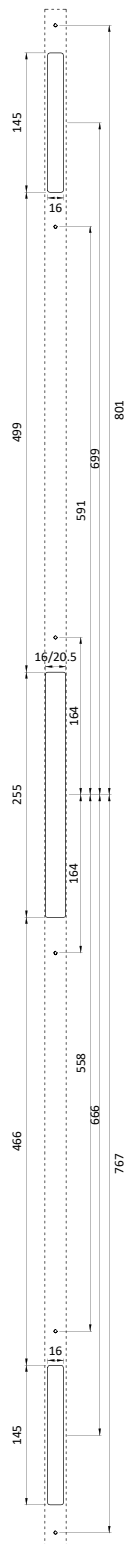

7716

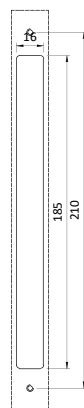

7791
7791S

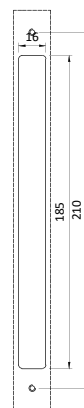

7795
7798

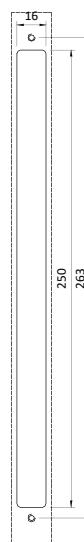

7797

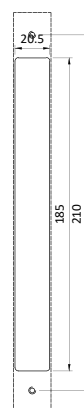

FECHADURAS FORNECIDAS COM CILINDRO / LOCKS PROVIDED WITH CYLINDER /
CERRADURAS VENDIDAS CON CILINDRO / SERRURES FOURNI AVEC CYLINDRE

- 7706
- 7796
- 7791 S
- 7794
- 7795
- 9791 S
- 9795
- 9797
- 5790
- 5792

* O resto das fechaduras que estejam apresentadas neste catálogo com cilindro, não são fornecidas com cilindro.

* Other locks, despite being shown with cylinder in this catalog, they are not provided with them.

* El resto de las cerraduras, a pesar de mostrarse con cilindro en este catálogo, no son vendidas con él.

* Autres serrures, en dépit d'être montré avec cylindre dans ce catalogue, ils ne sont pas fournis avec eux.

DR ACCESSORIES - ERRETI - GNS - SOTRALU
are companies of



DR ACCESSORIES

Zona Industriale Squartabue n.nc
62019 Recanati (MC)
ITALY
tel. +39 0717 506 174
info@ragni-fr.com
www.fraccessories.com

ERRETI

Via Pilastrino 32/B
48031 Bagnara di Romagna (RA)
ITALY
tel. +39 0545 283 811
sales@erreti.com
www.erreti.com

GNS

E.N. 1- Mouisca do Vouga
3754-901 Águeda
PORTUGAL
tel. +351 234 644 224
info@ingns.com
www.ingns.com

SOTRALU

151, avenue des Pyrénées
31600 Muret
FRANCE
tel. +33 5 34 46 06 00
contact@sotralu.fr
www.sotralu.fr

BELIEFS SERVING OUR CUSTOMERS:

For Sotralu Group, technical excellence is worth having only if it is in line with the ethical principles related to human dignity and working conditions, and with the concern of preserving our planet. By integrating disabled persons, contributing in providing jobs to the unemployed and ensuring the respect of these values by our suppliers: sustainable and fair quality is created every day in all the aspects of our activity.